

WESTERN AVIONICS

**DUAL STANAG 3838/3910
VME INTERFACE BOARD**

P/N 1U10997G01 Rev A

**User Manual
UM 10997 Rev B**

**© Western Avionics Ltd.
13/14 Shannon Free Zone
Co. Clare
Ireland**

9 July 2002

1	GENERAL INFORMATION	6
1.1	INTRODUCTION	6
1.2	MANUAL DESCRIPTION	6
1.3	SYSTEM CHARACTERISTICS AND SPECIFICATIONS	7
1.4	CAPABILITIES	8
1.4.1	General	8
1.4.2	Bus Controller (BC) Features (With MRT Simulation and Data Monitoring)	8
1.4.3	Multiple Remote Terminal (MRT) Features	9
1.4.4	Chronological Bus Monitor (CM) Features	9
1.5	VME-4220 ARCHITECTURE	10
1.6	BUS COUPLING MATRIX	11
1.7	PROTOCOL MANAGEMENT UNIT	11
1.8	3838 INTERFACE	11
1.9	HS 3910 INTERFACE	11
1.10	STORAGE DATA	12
1.11	TOOLS AND TEST EQUIPMENT	12
1.12	SAFETY PRECAUTIONS	12
2	INSTALLATION AND PREPARATION FOR USE	15
2.1	GENERAL	15
2.2	INSTALLATION OF VME-4220	15
2.3	TURN ON	15
2.4	SELFTEST	15
2.5	SPECIFIC 3838/3910 INTERFACE FEATURES	16
2.5.1	Clock features	16
2.5.2	IRIG-B Counter Features	16
2.5.3	Trigger-In Features	16
2.5.4	Trigger Out Features	16
2.6	VME INTERFACE	17
2.6.1	Introduction	17
2.6.2	Details	17
2.6.3	Electrical Characteristics	17
2.6.4	Capabilities	18
2.7	3838 INTERFACE	18
2.7.1	Introduction	18
2.7.2	Electrical Characteristics	18
3	VME-4220 OPERATION	19
3.1	INTRODUCTION	19
3.2	CONVENTIONS	19
3.3	ORGANISATION DIAGRAM	19
3.4	BASE REGISTERS	19
3.4.1	Base Register Names and Location	21
3.4.2	Base Register Descriptions	22
3.5	REMOTE TERMINAL SIMULATION TABLE	32
3.5.1	Simulation Type Word	32
3.5.2	Status Word	33
3.5.3	LS Last Command Word	33
3.5.4	LS Bit Word	33
3.5.5	HS Status Word	33
3.5.6	HS Last Action	33
3.5.7	HS Bit Word	33

4	BUS CONTROLLER MODE OF OPERATION	34
4.1	INTRODUCTION.....	34
4.2	MESSAGE DESCRIPTOR BLOCK (MDB).....	35
4.2.1	<i>Message Number (00H)</i>	35
4.2.2	<i>LS Event Mask (02H)</i>	35
4.2.3	<i>Message Type Word (04H)</i>	36
4.2.4	<i>LS Message Error Phase Definition (06H)</i>	37
4.2.5	<i>LS Message Error Description Word (08H)</i>	37
4.2.6	<i>Address in Look-Up Table (0AH)</i>	38
4.2.7	<i>Command Word 1 (0CH)</i>	38
4.2.8	<i>Command Word 2 (0EH)</i>	38
4.2.9	<i>Action Word 1 (10H)</i>	38
4.2.10	<i>Action Word 2 (12H)</i>	38
4.2.11	<i>Retry Subroutine Absolute Address (14H)</i>	38
4.2.12	<i>HS Event Mask (16H)</i>	39
4.2.13	<i>Inter-message Gap Time (18H)</i>	39
4.2.14	<i>HS RT-RT Inter-message Gap Time (1AH)</i>	39
4.2.15	<i>Status Word 1 (1CH)</i>	39
4.2.16	<i>Status Word 2 (1EH)</i>	39
4.3	DATA BUFFERS SIMULATION AND MONITORING.....	40
4.3.1	<i>Look-Up-Table</i>	41
4.3.2	<i>Data Descriptor Block</i>	41
4.3.3	<i>Data Buffers</i>	45
4.4	MODE COMMANDS.....	46
4.5	INTERRUPT REQUESTS.....	47
4.5.1	<i>Interrupt Coding</i>	47
4.5.2	<i>Set Message Interrupts</i>	47
4.5.3	<i>Message Status Report Queue</i>	48
5	MULTIPLE REMOTE TERMINAL MODE OF OPERATION	49
5.1	INTRODUCTION.....	49
5.2	LOOK-UP-TABLES.....	50
5.3	MODE COMMANDS SPECIFICATIONS.....	50
5.4	DATA WORDS STORAGE.....	50
5.5	LS ERROR INJECTION DEFINITION.....	50
5.5.1	<i>Global RT Error Description Word (RT Simulation Table)</i>	51
5.5.2	<i>Message Error Injection Word (Look-up-Table)</i>	52
5.6	INTERRUPTS CODING.....	54
5.6.1	<i>Low and High Priority Interrupts (two word code)</i>	54
5.6.2	<i>Message Interrupts (or set of messages interrupt)</i>	54
5.6.3	<i>Status Report Queue (two words per report)</i>	54
5.7	SPECIFIC FUNCTIONS.....	55
5.7.1	<i>Data Message Reception</i>	55
5.7.2	<i>Reception of Mode Commands Data Words</i>	55
5.7.3	<i>Mode Command "Synchronise with Data Word"</i>	55
5.7.4	<i>Frequency Toggle</i>	55
5.7.5	<i>Programmable HS RI / TI Time in DDB</i>	55

6	CHRONOLOGICAL BUS MONITOR MODE OF OPERATION.....	56
6.1	INTRODUCTION.....	56
6.2	BASE REGISTERS.....	56
6.2.1	Control Register (Write) (00H).....	57
6.2.2	Command Register (CR).....	57
6.2.3	Status Register (SR).....	58
6.2.4	Transformer/Direct Coupling Select Register.....	58
6.2.5	HS Subaddress Register.....	58
6.2.6	IRQ Selection Register (34H).....	58
6.2.7	Load Clock HI/LO Registers (+38H1 / +3AH).....	59
6.2.8	Current Address Register (CAR) (+42H).....	59
6.2.9	Trigger Occurrence Register (TOR) (+44H).....	59
6.2.10	Trigger Set-up Pointer (TSP) (+46H).....	59
6.3	DETAILED TRIGGER DESCRIPTION.....	60
6.4	STACK DATA FORMAT.....	70
6.4.1	Previous Address Pointer.....	70
6.4.2	Time Stamp HI/LO.....	70
6.4.3	Data.....	70
6.4.4	Next Address Pointer.....	71
6.4.5	RT Response Time 1/2.....	71
6.5	3910 DATA FORMAT.....	72
6.5.1	Flow Diagram.....	72

List of Figures

Figure 1-1	VME-4220 Board Functional Block Diagram	10
Figure 1-2	Front Panel connectors & indicators diagram	13
Figure 1-3	Location of Address Switches and Linkers diagram.....	14
Figure 2-1	VME Switches	17
Figure 3-1	Organisation Diagram	20
Figure 4-1	Bus Controller Organisation Diagram.....	34
Figure 4-2	Data Buffers Simulation and Monitoring	40
Figure 5-1	Multiple Remote Terminal Organisation Diagram.....	49

List of Tables

Table 1-1	3838 Connector Pinouts (Pri & Sec, A & B).....	13
Table 1-2	9 Way I/O Connector Pinouts (J5).....	13
Table 3-1	Base Register Names and Locations.....	21
Table 3-2	Command Register (CR).....	24
Table 3-3	Status Register	25
Table 3-4	Remote Terminal Simulation Table	32
Table 4-1	Message Descriptor Block.....	35
Table 4-2	Data Descriptor Block.....	41
Table 4-3	Data Buffers	46
Table 6-1	Base Registers	56
Table 6-2	Command Registers.....	57
Table 6-3	Status Registers.....	58
Table 6-4	Stack Data Format.....	70
Table 6-5	Stack Messages.....	72

1 GENERAL INFORMATION

1.1 INTRODUCTION

The VME-4220 Intelligent Interface Board is a VME card designed to meet the requirements of both STANAG 3838 and STANAG 3910. The VME-4220 is a standard 6U size VME card allowing up to two independent 3838/3910 modules to be used, in a variety of combinations, to provide up to two Bus Controller, Multi-Remote Terminal with Monitoring functions, or one Bus Controller, Multi-Remote Terminal, and Chronological Bus Monitors on a single VME card.

The VME-4220 provides a powerful and intelligent interface between VME based host equipment and the STANAG 3838 / STANAG 3910 data buses, providing comprehensive test and simulation functions.

1.2 MANUAL DESCRIPTION

The following paragraphs provide a general description of the manual layout and content:

- **Section 1** **General Information** - contains a brief description of the manual, and a general description of VME-4220. This section also contains the architecture, protocol management, STANAG 3838 interface information, STANAG 3910 interface information, instrument specifications, information concerning accessories, furnished items, and also safety precautions.
- **Section 2** **Installation and Preparation for Use** - contains instructions on installation, preparation for use, self-test and reset of VME-4220.
- **Section 3** **Operation** - contains a functional description of VME-4220 and operating procedures necessary to run VME-4220.
- **Section 4** **Bus Controller Mode of Operation** - contains information on the mode of operation for the Bus Controller of VME-4220.
- **Section 5** **Multiple Remote Terminal Mode of Operation** - contains information on the mode of operation for the Multiple Remote Terminals of VME-4220.
- **Section 6** **Chronological Bus Monitor Mode of Operation** - contains information on the mode of operation for the Chronological Bus Monitor of VME-4220.

1.3 SYSTEM CHARACTERISTICS AND SPECIFICATIONS

The characteristics and specifications of VME-4220 are listed as follows:

- **VME:**
 - Memory mapped real-time VME interface.
 - VME Interface; Slave A32, D32, D16, D8, Block Transfers.
- **BITE:** 95% Confidence Level.
- **Weight:** 440 grams (>1 lb.)
- **Power**
 - + 5Vdc 1.45 A max.
 - +12Vdc 250mA max.
 - 12Vdc 50mA max.
- **Temperature:**
 - Operating: 0°C to +50°C
 - Non-operating: -20°C to +70°C
- **Humidity:**
 - 0°C to +29°C: 95% RH
 - 30°C to +40°C: 75% RH
- **Front Panel 3838 Connectors** Tri-axial type CBBJR79
- **Front Panel 3910 Electrical Connectors** Co-axial type CBBJR29
- **Front Panel 3910 Optical Connectors** Deutsch 454596 (N)
- **Front Panel I/O Connector** 9 way micro-miniature to MIL-C-83513/02-AN
- **LED Indicators**
 - Power-on indicator (Green) Pwr
 - VME activity (Yellow) Act
 - BIT-Bus A Fail (Red) Fail
 - BIT-Bus B Fail (Red) Fail
 - BUS-A Activity (Yellow) Busy
 - BUS-B Activity (Yellow) Busy
 - IRIG-B Lock, Bus A (Yellow) Lock
 - IRIG-B Lock, Bus B (Yellow) Lock

1.4 CAPABILITIES

VME-4220 is capable of the following functions:

1.4.1 General

- Memory mapped real-time VME access.
- Simultaneous control of up to two STANAG 3838 dual redundant buses.
- Full STANAG 3910 control on one bus in BC, MRT or BC+MRT mode with simultaneous STANAG 3910 bus monitoring on second bus.
- HS transceivers interface for either fibre optic or electrical transceivers
- 8MByte of RAM per 3838/3910 bus.
- Two Vectored Interrupts per 3838/3910 bus.
- 3838 data protocol managed by a micro-controller providing flexibility and extensibility.
- Full Error Injection capability.
- External Triggers.
- Internal Self-tests.
- Standard single slot VME board. (6U)

1.4.2 Bus Controller (BC) Features (With MRT Simulation and Data Monitoring)

- Bus Control:
 - Autonomous frame control using comprehensive set of instructions and message descriptor blocks.
 - Acyclic message insertion.
 - Error injection.
 - Frame frequency selection.
 - Inter-message gap selection.
 - Response time-out selection.
 - Bus events detection, mask, storage, and reporting (bus errors, status word bits).
- Simultaneous MRT Simulation (up to 31).
- Data Words Transfers:
 - Data buffer simulation for the BC and the simulated RT's.
 - Sub-address based data buffer access with data descriptor blocks defining each bus message;
 - Multi-buffering (linked buffers or frequency-toggled buffers).
 - Vectored interrupts section (two different interrupts with vector queues).
 - Data status report.
 - Data buffer time tagging.
- Simultaneous monitoring of all data buffers.

1.4.3 Multiple Remote Terminal (MRT) Features

- Simulation:
 - Up to 31 - RT simulations.
 - Mode and Broadcast commands handling.
 - Error Injection.
- Data Words Transfers:
 - Data buffer simulation for simulated RTs.
 - Sub-address based data buffer access offering the same powerful data buffering as in the bus controller mode.
 - All non-transmitted data messages are monitored.

1.4.4 Chronological Bus Monitor (CM) Features

- Capture of all bus activity in chronological stack, with time tagging of each message.
- Comprehensive multi-trigger facilities allowing selective capture and interrupts to be performed on complex data sequence.
- Cyclical stack up to 8Mbyte, with interrupt on completion of capture.
- All 3838 and 3910 errors detected.

1.6 BUS COUPLING MATRIX

This matrix allows the user to define the STANAG 3838 buses as direct or stub coupled. It also allows interconnections to be made between the buses. This enables the two STANAG 3838 buses to be connected without the need of external coupling and interconnections. Control of this matrix is achieved via the control register of the BUS 1 interface.

1.7 PROTOCOL MANAGEMENT UNIT

A micro-controller based structure running at 40Mhz handles the management of the 3838 and 3910 protocol for each of the operating modes (BC, MRT, BM). The micro-controller works each of the 3838 command, status and data words functions of its operating mode and the configuration tables in RAM. The micro-controller directly drives word by word the 3838 interface, and initiates the HS 3910 interface depending on the HS action word messages running on the 3838 lines. The micro-controller management unit allows flexibility and expandability as well as for the bus control tasks as for the user interface.

1.8 3838 INTERFACE

The 3838 interface is a dual redundant interface, which includes a standard dual redundant transceiver and a Manchester encoder/decoder with full error detection and error injection capabilities, which include:

- Manchester bit error
- Synch bit error
- Parity error
- Word length error
- Wrong bus error
- Both bus error
- Response time error

1.9 HS 3910 INTERFACE

The HS 3910 interface includes clock recovery, encoder/decoder, and HS frame control functions with error detection and error injection capabilities:

- Preamble bit count error
- Word count error (+ or -)
 - Start/End delimiter pattern error
 - Bit count error
- Frame check sequence (FCS) error
- Manchester bit error

HS transmitter initialisation time TI, and HS receiver initialisation timeout RIout are programmable. This 3910 interface drives either an on-board non-redundant HS electrical transceiver or external dual redundant HS fibre optic transceivers. This interface is controlled by the micro-controller but is directly connected by DMA to the RAM transfer the HS data words.

1.10 STORAGE DATA

As the VME-4220 contains electrostatic sensitive devices (ESD's), special storage and handling is required. Do not store near electrostatic, electromagnetic, magnetic or radiation fields.

1.11 TOOLS AND TEST EQUIPMENT

No special tools or test equipment is required to test the VME-4220.

1.12 SAFETY PRECAUTIONS

Operating personnel must observe safety regulations at all times, refer to the Safety Summary at the front of this manual.

WARNING

Potentially hazardous voltages exist on the host computer power supply.
Do not attempt to install or remove the VME-4220 without first removing main power.
Improper handling can cause injury or death.

FRONT PANEL CONNECTORS AND INDICATORS

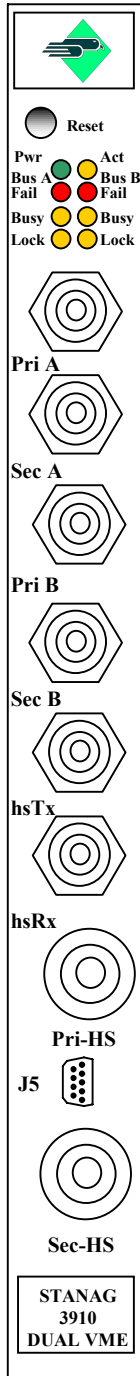

Table 1-1 3838 Connector Pinouts (Pri & Sec, A & B)

PIN	DESCRIPTION
INNER	3838 POSITIVE
OUTER	3838 NEGATIVE
CASE	GROUND SHEILD

Table 1-2 9 Way I/O Connector Pinouts (J5)

PIN #	DESCRIPTION
1	TRIGGER-OUT A, Collector
2	TRIGGER-OUT A, Emitter
3	TRIGGER-OUT B, Collector
4	TRIGGER-OUT B, Emitter
5	TRIGGER-IN A, Anode
6	TRIGGER-IN A, Cathode
7	TRIGGER-IN B, Anode
8	TRIGGER-IN B, Cathode
9	IRIG-B Input

Figure 1-2 Front Panel connectors & indicators diagram

Locations of linker blocks Z1, Z2, Z3, Z4 & SW1 and SW2

Hexadecimal address switches SW1 and SW2 are located at top edge of the board, as shown below

LK1, LK2, LK3, LK4 and LK5 are 3 way headers used to configure the card for Electrical or Optical operation, normally supplied factory configured .

Z1 is a 2-pin header, provided to allow use on on-card 75 Ohm load terminator for the IRIG-B supply, which is applied when linker fitted. Z2 and Z3 are 2-pin headers that require a linker to be fitted when performing a firmware up-grade, provided by means of self-loading .exe files.

Z4 is a 2-pin header, that when fitted with a linker connects the internal VMEFAIL signal to the SYSFAIL on the VME backplane.

PP1 and PP2 are 3-pin headers used for initial factory loading of on-card device programming, and must not be used by customers.

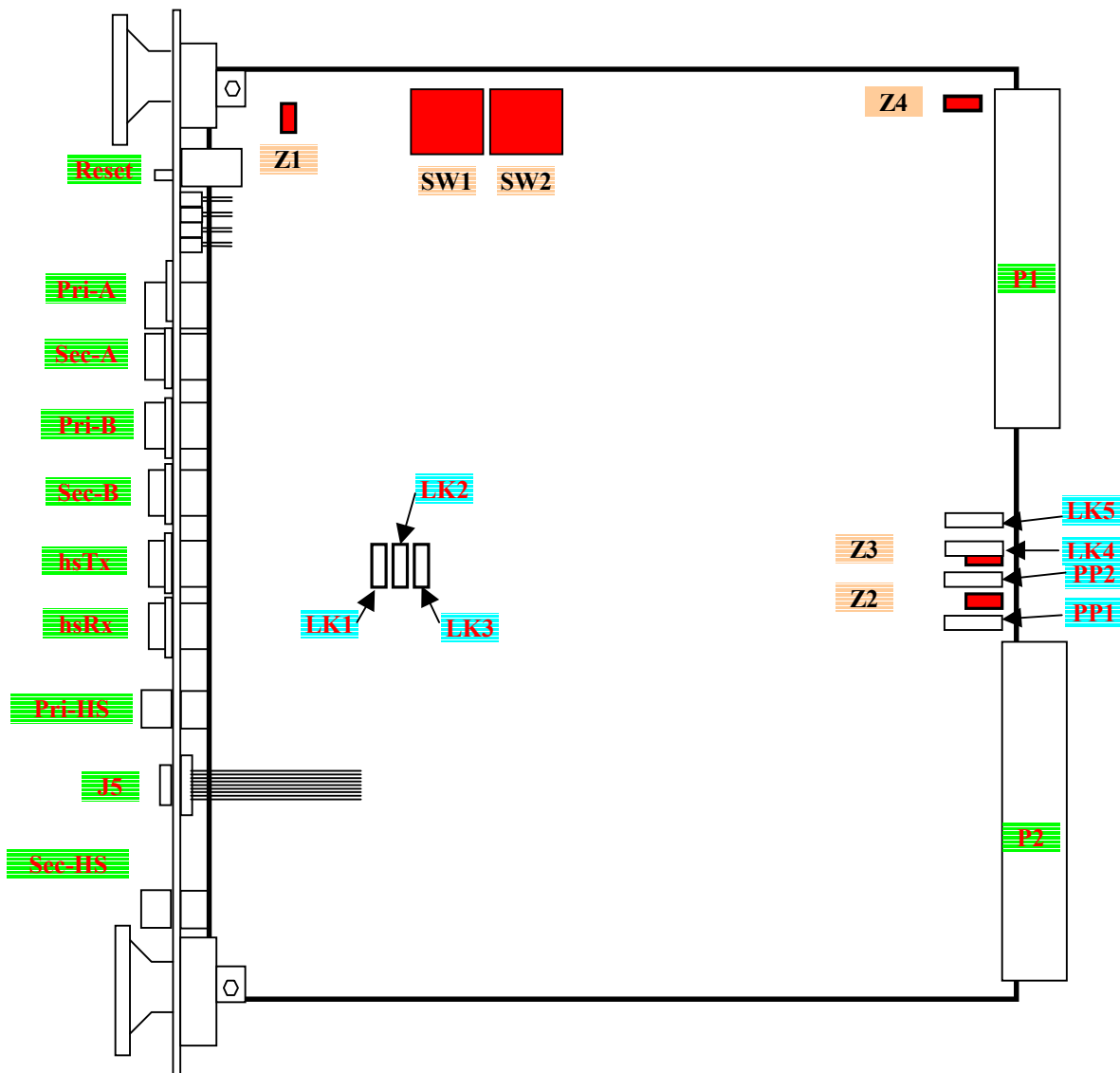

Figure 1-3 Location of Address Switches and Linkers diagram

2 INSTALLATION AND PREPARATION FOR USE

2.1 GENERAL

On delivery, inspect the unit for possible damage. If it is damaged, notify the shipping company, and contact your distributor, or Western Avionics, for details of return procedure. When unpacking remove all protective covering and store covering, as unit may need to be reshipped at a later date.

CAUTION

The 4220 contain Electrostatic Sensitive Devices (ESD's).
Observe ESD handling requirements, and do not ship or store near
electro-static, electromagnetic, magnetic or radioactive fields.

2.2 INSTALLATION OF VME-4220

Prior to installing VME-4220 into the rack, ensure that all power has been removed from the rack.

2.3 TURN ON

Set mains power on rack to ON.

The VME-4220 will perform system self-test on the BC, MRT and CM features of both Bus 1 and Bus 2, lasting approximately three seconds. In the event of a failure of any part of the BIT on either Bus 1 or Bus 2, LED's will light on the front panel (BIT-1, BIT-2) indicating the section that has failed.

2.4 SELFTEST

After applying power to the VME-4220, or performing a software or hardware re-set, system self-test will be performed.

The VME-4220 will perform system self-test on the BC, MRT and CM features of both Bus 1 and Bus 2, lasting approximately three seconds. In the event of a failure of any part of the BIT on either Bus 1 or Bus 2, LED's will light on the front panel (BIT-1, BIT-2) indicating the section that has failed

2.5 SPECIFIC 3838/3910 INTERFACE FEATURES

2.5.1 Clock features

The local clock can be one of two types depending on the module firmware type used.

If the module firmware type is standard 32 bit clock then the format will be a 32 bit binary clock that will have an LSB of 10uS for BC-MRT and MRT operations and 0.5uS for CHRON-MON operations.

If the module firmware type is IRIG-B then the clock format will be as follows:

2.5.2 IRIG-B Counter Features

This 4 x 16-bit word counter can be setup to decode incoming IRIG-B serial time code or programmed to free-run. This counter reports the date and time of day accurate to +/- 0.5uS. The value of this register can be read via the Clock HI and Clock LO base registers. When free-running, this counter can be pre-set/updated by the user. The format of this clock is as follows:

The first 3 values will be the current clock time as decoded from the IRIG-B time code. The last 16-bit word will be a value 0-1999 defining the fraction of a millisecond with a resolution of 0.5uS per tick.

1 st word:	N0 CC DDDDDDD HHHHH	C = Days x 100, D = Days, H = Hours
2 nd word:	0000 MMMMMM SSSSS	M = Minutes, S = Seconds
3 rd word:	000000 MMMMMMMMMM	M = Milliseconds
4 th word:	00000 UUUUUUUUUU	U = 0.5uS ticks

If the MSB of the 1st word (N) is set, the card is not locked with the incoming IRIG-B signal.

Note:

The remainder of this document refers to all clock and time-tag information as standard 32-bit. This clock mode results in 2 x 16bit words being stored in the data buffers. If the firmware module is IRIG-B then all time-tags will be stored as 4 x 16bit words.

2.5.3 Trigger-In Features

Trigger-In enters the board logic through the 15 way front panel connector and then an opto-coupler. So, if the diode is powered there is a zero logic level, and if the diode is not powered there is a high logic level. So, a rising edge on this logic level can be used for hardware starts of the frame, hardware starts of the minor cycle, or external trigger for the bus monitor. One Trigger-in is provided for Bus 1 and for Bus-2.

2.5.4 Trigger Out Features

Trigger-Out is in fact a bit in a register accessible by the on-board processor to indicate to the external world that an event has been detected. This event can be as follows:

- Beginning of the minor cycle
- Beginning of a message
- Bus Monitor trigger detected

Trigger-Out exits the board through an opto-coupler and the 15-way front panel connector, see Figure 1-2 for details. One Trigger-out is provided for Bus 1 and for Bus-2.

2.6 VME INTERFACE

2.6.1 Introduction

The 4220 board is used as a 16Mbyte field.

- R/W DRAM (16Mbyte).
- Read only 32-bit counter or IRIG-B format clock.
- Write only 16-bit register (one 16-bit access).

The Control Register and the counter are mapped into the memory field. Two hex switches on the board define the starting address of the board as shown below. The VME interface includes a VME slave and two VME interrupters.

Figure 2-1 VME Switches

SW1		SW2	
31	28	27	24

- A32 only access for memory, register, counters.
- Address only transfers without loss of data.
- D32, D16, D08 (EO) for memory access.
- D16 for register access.
- Block Transfers into memory (32-bit, 16-bit, 8-bit access).
- Read-Modify-Write into memory (32-bit, 16-bit, 8-bit access).
- Aligned transfer only.
- VME interrupts (High and Low Interrupts):
 - Programmable level (1-7).
 - Programmable daisy chains (enable and disable).
 - Programmable 8-bit Status/ID (vector) D08(0)
(Accept 32-bit, 16-bit, 8-bit interrupt handler size).
 - Programmable interrupt release.
ROAK: Release interrupt during interrupt acknowledge cycle or during register access.
RORA: Release interrupt during register access only.
 - Interrupters can interrupt in the same level.

2.6.2 Details

- Access rate average: 5Mbyte/s
- Address Modifiers:

To access the memory, the counter, the register:

- A32 single access and read-modify-write; 09h, 0Ah, 0Dh, 0Eh
- A32 block transfers; 0Bh, 0Fh

2.6.3 Electrical Characteristics

- +5V and +12V.
- All driving and loading rules are respected.

2.6.4 Capabilities

Each VME-4220 3838/3910 interface is addressed as a 8Mbyte field.

- R/W DRAM (8Mbyte).
- Read only counter/clock.
- Write only 16-bit register (one 16-bit access).

2.7 3838 INTERFACE

2.7.1 Introduction

The interface matches the MIL-STD 3838 Standard.

2.7.2 Electrical Characteristics

Each 3838 interface provides one dual redundant bus.

- Primary bus.
- Secondary bus.

Each 3838 interface can be:

- Transformer coupled.
- Direct coupled.
- Amplitude controlled.

3 VME-4220 OPERATION

3.1 INTRODUCTION

The VME-4220 provides Bus Controller (BC), Multi-Remote Terminal (MRT), and Chronological Bus Monitor (CM) functions either independently or simultaneously. In order to run any of these functions, information must be loaded into specific fixed register locations (Base Registers). Some of these registers contain pointers to other areas of memory/registers. The selection of these pointers is left up to the discretion of the user. Therefore, memory blocks can be positioned in the on-board memory to suit user requirements. This setup means that fixed position registers are minimal.

3.2 CONVENTIONS

The architecture of both 3838 interfaces is identical allowing two independent low speed interfaces.

However, if the card is to be used on 3910 buses, the second module can only receive 3910 data. This feature allows the primary module to be set up as a BC, MRT or BC+MRT and the secondary module to be set up as a Chronological Monitor capable of triggering and capturing all 3838 and 3910 data simultaneous with the operation of the primary module.

BASE = Base address of module. The primary module base address is the base address of the card.
The secondary module resides at the base address of the card + 8 Mbytes.

The memory range BASE+10000H to End of Memory 3838/3910 interface is reserved for the 3838/3910 data blocks. All other data must reside in the first 64Kbytes.

After a Power-On:

- On-board processor doing its power-on initialisation,
 - Then executing Self-Test (BIT).
 - Then waiting for a user command.
- DSI per default (insertion program is disabled)

3.3 ORGANISATION DIAGRAM

The organisation diagram figure 3-1 shows how the functional areas of the VME-4220 3838/3910 interfaces can be controlled.

3.4 BASE REGISTERS

The only fixed position registers are the Base Registers. The Base Registers are the starting points for a description of operation of any of the three modes of operation, (BC, MRT and CM).

They are located starting at the module Base Address.

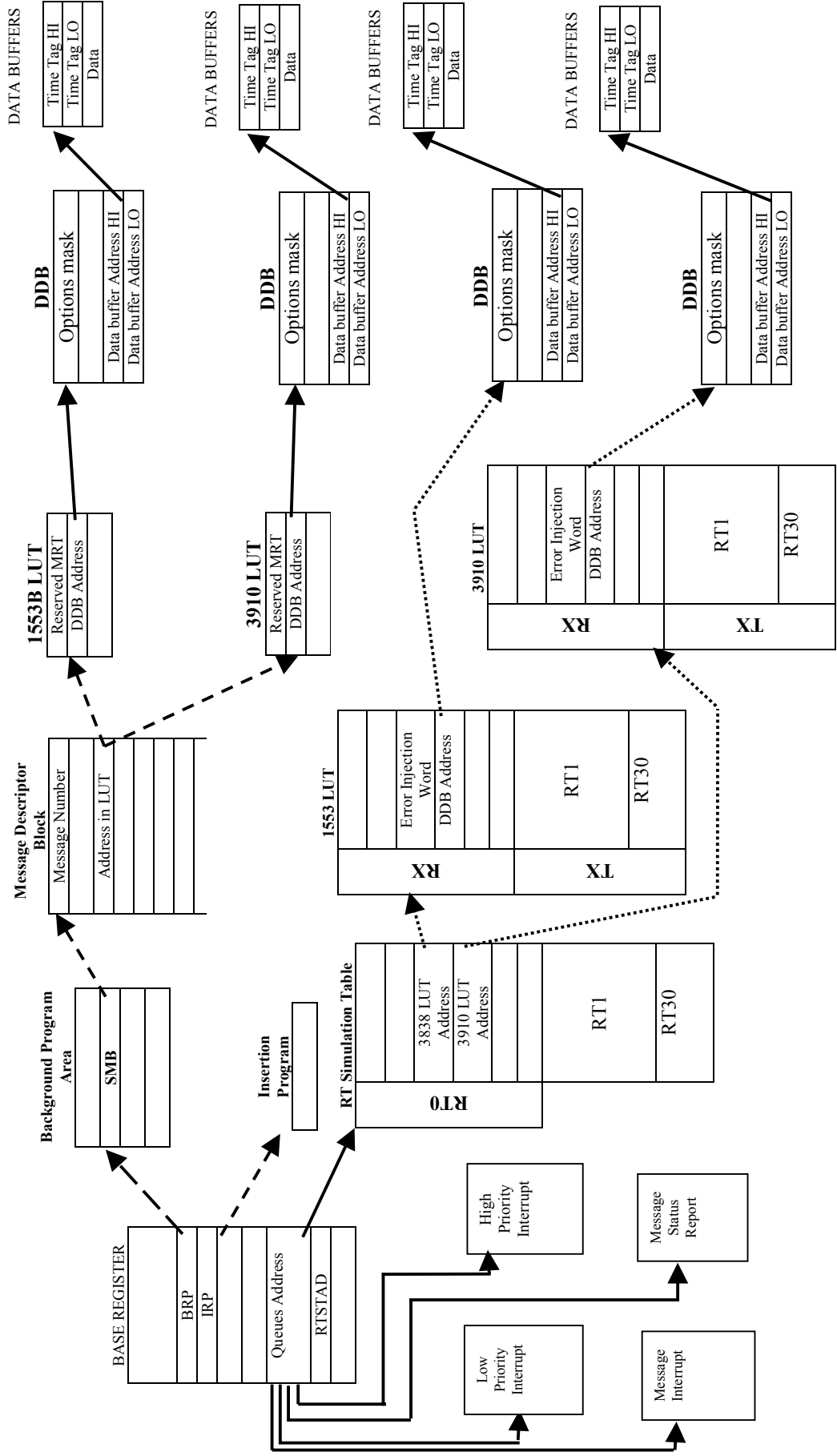

Figure 3-1 Organisation Diagram

3.4.1 Base Register Names and Location

The names and locations of the Base Registers are contained in table 3-1.

Table 3-1. Base Register Names and Locations

BASE	Control Register(Write)/Clock HI Word (Read)
+02H	Clock LO Word (Read only)
+04H	Command Register (CR)
+06H	Status Register (SR)
+08H	Background Running Pointer (BRP) Address of Program
+0AH	Insertion Running Pointer (IRP) Address of Program
+0CH	Reserved
+0EH	Low Priority Interrupt Queue Start Address Pointer
+10H	Reserved
+12H	High Priority Interrupt Queue Start Address Pointer
+14H	Reserved
+16H	Message Interrupt Queue Start Address Pointer
+18H	Reserved
+1AH	Status Report Queue Start Address Pointer
+1CH	Reserved
+1EH	RT Simulation Table Address Register (RTSTAD)
+20H	Amplitude Register
+22H	Coupling Register
+24H	Toggle Buffer Address Offset (MSB=1 Global Enable)
+26H	SET OF MESSAGES Start Address
+28H	Global RT Response Time Register (μ s)
+2AH	RT No Response Timeout Register (μ s)
+2CH	HS Subaddress Register
+2EH	Reserved
+30H	Reserved
+32H	Reserved
+34H	IRQ Selection Register
+36H	Minor Frame Counter Register
+38H	Load Clock HI Register
+3AH	Load Clock LO Register
+3CH	Test and Set register (TASR)
+3EH	Service Request Queue Address Pointer (SRQADSP)
+40H	Cycling Interrupt Update Register
+42H	Monitor Current Address Register (CAR)
+44H	Monitor Trigger Occurrence Register (TOR)
+46H	Monitor Trigger Set-up Pointer (TSP)
+48H	PRI Bus 3838 RT TX inhibit bits HI
+4AH	PRI Bus 3838 RT TX inhibit bits LO
+4CH	SEC Bus 3838 RT TX inhibit bits HI
+4EH	SEC Bus 3838 RT TX inhibit bits LO
+50H	PRI Bus 3910 RT TX inhibit bits HI
+52H	PRI Bus 3910 RT TX inhibit bits LO
+54H	SEC Bus 3910 RT TX inhibit bits HI
+56H	SEC Bus 3910 RT TX inhibit bits LO

3.4.2 Base Register Descriptions

The Base Register functions are defined in the following paragraphs.

3.4.2.1 Control Register (Write) (00H)

D15	D14	D13	D12	D11	D10	D09	D08	D07	D06	D05	D04	D03	D02	D01	D00
BE	BM	CE	CM	FE	FS	0	RS	0	0	0	V2	V1	0	C1	C0

- CO Clear => Request
- CI Clear => Insertion Request
- VI Set => Release VME1 IRQ
- V2 Set => Release VME2 IRQ
- RS Clear => 3838 interface is held in RESET
- FS => With the FE bit set this bit shall define the firmware selection for the interface.

FE	FS	
0	0	No change
0	1	No change
1	0	Standard firmware selected
1	1	Second enhanced/custom firmware selected

Note: After selecting a new firmware, the user must reset the interface by Taking RS LO the HI. Default is standard firmware.

- CM => With the CE bit set this bit shall define the clock type to use

CE	CM	
0	0	No change
0	1	No change
1	0	32 bit clock
1	1	IRIG-B clock

Note: Default is 32 bit clock.

- BM => With the BE bit set this bit shall define the bus coupling for the two buses.

CE	CM	
0	0	No change
0	1	No change
1	0	Separate buses
1	1	Buses joined

- Note:
1. Default is separate buses.
 2. The BM/BE bits are only applicable for the primary module.
- The control register at address 800000 does not control the bus mode.

Example: 0102H generates a command request while keeping RS set.

3.4.2.2 Clock HI/LO read register (00H/02H)

For the standard 32 bit clock a read HI followed by a read LO will report the current value of the 32 bit clock.

For IRIG-B type modules the clock read is done as follows:

These two registers are for reading the current value of the on-board clock. A read of the Clock HI will request the current value of the clock to be latched into the output buffer. The user must wait a minimum time of >0.5uS before beginning to read the clock value to ensure latching has completed. Four consecutive reads of the Clock LO location will return the clock value as: -

1 st word:	N0 CC DDDDDDDD HHHHH	C = Days x 100, D = Days, H = Hours
2 nd word:	0000 MMMMMM SSSSSS	M = Minutes, S = Seconds
3 rd word:	000000 MMMMMMMMMM	M = Milliseconds
4 th word:	00000 UUUUUUUUUU	U = 0.5uS ticks

If the MSB of the 1st word (N) is set, the card is not locked with the incoming IRIG-B signal.

To **Load** the clock with a new value:

1. Write the new value in the module base registers Load Clock HGH, LOW.

1 st word:	LL CC DDDDDDDD HHHH
2 nd word:	HH MMMMMM SSSSSS

LL	Leap year	(0-3)
CC	Days x 100	(0-3)
DDDDDDDD	Days	(0-66 in BCD)
HHHHHH	Hours	(0-23 in BCD)
MMMMMM	Minutes	(0-59 in BCD)
SSSSSS	Seconds	(0-59 in BCD)

To allow decoding of IRIG-B the clock always adds 1 second to the programmed value. Therefore, the above time must be set to the desired time minus 1 second. Leap year value should be 00 = Leap year, 01 = 1st year after leap year etc.

2. Write the Load Clock command code into the command register.
3. Now execute generate a command request (write 0x0302 in control register).

If the 1st word is set to LL111111111111, the free running clock will not be loaded. The LL bits will be used to define the leap year and the clock will be forced into external sync mode.

If the 1st word is **not** set to LL111111111111, the free running clock will be loaded and the clock will be forced into free running mode.

3.4.2.3 Command Register (CR) (04H)

Prior to clearing the command request bit (CO) in the control register, the user must first test that the command register is clear. When the command register is clear the user can insert the next command to be executed. After the command is loaded, bit CO in the control register can be cleared. When the command register clears, the board is ready for a new command. Refer to table 3-2.

3.4.2.4 Command Register (CR) (04H)

Prior to clearing the command request bit (CO) in the control register, the user must first test that the command register is clear. When the command register is clear the user can insert the next command to be executed. After the command is loaded, bit CO in the control register can be cleared. When the command register clears, the board is ready for a new command. Refer to table 3-2.

Table 3-2 Command Register (CR)

CODE	COMMAND
0000H	Illegal
0001H	GO TO BC MODE
0002H	GO TO MRT MODE
0003H	GO TO MON MODE
0004H	BC COLD Start
0005H	BC WARM Start
0006H	BC STOP
0007H	MRT COLD Start
0008H	MRT WARM Start
0009H	MRT STOP
000AH	PAUSE
000BH	UNPAUSE
000CH	LOAD CLOCK
000DH	SELFTEST
000EH	RUN MONITOR
000FH	STOP MONITOR
0010H	Synchronise CLOCK

NOTE: PAUSE = Stop the Local clock. UNPAUSE = Restart the Local Clock

3.4.2.5 Status Register (SR) (06H)

The status register will contain a word reflecting the status of the board as shown in table 3-3.

Table 3-3 Status Register

CODE	STATUS
0001H	BC IDLE
0002H	MRT IDLE
0003H	MON IDLE
0004H	BC RUNNING
0005H	BC INSERTION RUNNING
8004H	BC PAUSED (Background)
8005H	BC PAUSED (Insertion)
9004H	EXECUTING SOFTWARE PAUSE (SWPSE)
A004H	EXECUTING HARDWARE PAUSE (HWPSE)
0006H	MRT RUNNING
8006H	MRT PAUSED
0007H	MON RUNNING
0008H	MON RUNNING
XXX8H	EXECUTING SELFTEST
	FINISHED SELFTEST

The status register will contain the following information after completion of self-test.

D15	D14	D13	D12	D11	D10	D09	D08	D07	D06	D05	D04	D03	D02	D01	D00
1	0	0	LS	HS	0	LC	M5	M4	M3	M2	M1	1	0	0	0

- LS = 1 3838 Interface Test Failed
- HS = 1 3910 Interface Test Failed
- LC = 1 Local Clock Test Failed
- M5 = 1 Memory Test 5 Failed
- M4 = 1 Memory Test 4 Failed
- M3 = 1 Memory Test 3 Failed
- M2 = 1 Memory Test 2 Failed
- M1 = 1 Memory Test 1 Failed

Several bits can be set simultaneously. If no self-test errors are detected the code in the status register will be 8008H.

3.4.2.6 Background Running Pointer (BRP) (08H)

In the BC mode, the Background Running Pointer (BRP) directs the firmware to the location of a background program, which can be used to organise the message sequencing. Before sending a BC start the user must initialise the BRP. BRP is updated by the on-board processor after executing a BC STOP command. Table 3-4 is a list of the possible instructions with descriptions and examples.

Table 3-4. Instruction Set Background Program

DELAY	:	0000H	XXXXH	XXXX= Delay LSB of 10µs
NOP1	:	0001H		PC = PC+1
NOP2	:	0002H		PC = PC+2
NOP3	:	0003H		PC = PC+3
BSR	:	0004H	XXXXH	XXXX = 16 bit signed branch to subroutine
BRA	:	0006H	XXXXH	XXXX = 16 bit signed branch
JMP	:	0007H	XXXXH	XXXX = 16 bit absolute address for jump
RTS	:	0008H		Return from subroutine
RTI	:	0009H		Return from insertion routine
ENI	:	000AH		Enable program insertion
DSI	:	000BH		Disable program insertion
LOOP	:	000CH	XXXXH	Load loop counter, with value XXXX
DBNE	:	000DH	XXXXH	LOOP = LOOP-1, If<>O branch signed offset XXXX
INITF	:	000EH	XXXXH	Initialise frame duration to XXXX (LSB = 10uS)
SWPSE	:	000FH		Wait for new on-board start of frame
HALT	:	0010H		End of BC program
SITL	:	0011H	XXXXH	Set low priority IRQ. Push XXXX on LO queue
SITH	:	0012H	XXXXH	Set high priority IRQ. Push XXXX on HI queue
HWPSE	:	0013H		wait for external Trig LO-HI for new frame
SMB	:	0014H	XXXXH	Send message. XXXXH = absolute address of MDB
TRGOUT	:	0015H	XXXXH	Trig out to the XXXXH level

- **Instructions:**

- **NOP (1, 2, 3);**
 - By a NOPx, the user can replace one, two or three instruction words.
- **BSR,BRA,DNBE;**
 - The offset is defined in bytes count (always even offset).
- **BSR;**
 - 15 levels of subroutines available.
- **TRGOUT xxxx**
 - Instructions to put TRIGOUT at 0 if xxxx = 0000H; or 1 if xxxx = 0001H.
 - On power-on, the output is on 0 level (per default).
- **LOOP xxxx;**
 - Load loop counter with value XXXX.
 - Only one level of loop.

- **INITF xxxx;**
 - XXXX = Minor frame duration (minor cycle time).
 - 10 µs for the LSB; the value for 20ms is 7D0H.
 - It must be initialised at the beginning of the background program.
 - This instruction resets the minor frame counter register.
- **SWPSE (Software Pause);**
 - To be put at the end of each minor cycle instruction list with the minor frame duration utility to have automatic minor frame restart.

Examples:

INITF xxxx

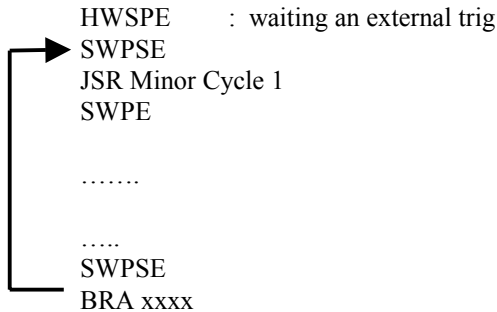

with Minor cycle X : SMB xxxx
 SMB xxxx

 RTS

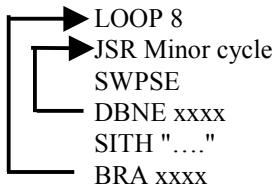

- Insertion Commands can be executed during SWPSE state.
- **HALT;**
 - On completion of this instruction the board will return to the BC idle state
 - To re-start the board: BC (Cold - Warm) Start (command register).
- **SITH xxxx / SITL xxxx;**
 - The on-board processor puts the value (code) xxxx in the cycling FIFO's.
 H => High Priority, L => Low Priority.
- **HWPSE (Hardware Pause);**
 - Restart by the external Trig In (external CK)
 - All the registers are not initialised:....
 - Used to synchronise messages of minor frames on external Trig In.

Example: See SWPSE above.

3.4.2.7 Insertion Running Pointer (IRP) (0AH)

The Insertion Running Pointer (IRP) has the same set of instructions as Instruction Set Background Program. To initiate an insertion the user must first load the IRP with the address of the insertion program. Then bit CI can be cleared in the control register.

- The background program can be interrupted by an insertion command.
- The insertion program cannot be interrupted by any other insertion command. In this case the second insertion request will be delayed until the end of the first one.
- Insertion program starting just before a minor cycle start will delay this one.
- IRP is updated by the on-board processor after executing a BC stop command.

3.4.2.8 Reserved (0CH)

3.4.2.9 LPIQAP (0EH) **Low priority interrupt queue start address.**

3.4.2.10 Reserved (10H)

3.4.2.11 HPIQAP (12H) **High priority interrupt queue start address.**

3.4.2.12 Reserved (14H)

3.4.2.13 MIQAP (16H) **Message interrupt queue start address.**

3.4.2.14 Reserved (18H)

3.4.2.15 SRQAP (1AH) **Status report queue start address.**

3.4.2.16 Reserved (1CH)

3.4.2.17 RTSTAD (1EH) **RT simulation table start address.**
Contains the address of the RT Simulation Tables, which defines the RT status when they are simulated.

3.4.2.18 Reserved (20H)

3.4.2.19 Reserved (22H)

3.4.2.20 Toggle Buffer Address Offset (24H)

- MSB = 1 : global toggle enable
 = 0 : no toggle
 offset : 15 bits

MSB	offset
15	14 0

- For a data buffer, if the toggle feature is selected (bit 15 = 1), the address of the toggle buffer is: (Buffer Address High + Toggle Buffer Offset), Buffer Address Low. [15 bits]
- For further details refer to paragraph 4-3.3.3.

3.4.2.21 Set of Messages Start Address (26H)

- This is the pointer of a 256-word table reserved to the on-board processor to compute the registers Set of Messages.
- For further details refer to paragraph 4-5.2.

3.4.2.22 Global RT Response Time Register (28H)

- This is the response time for all the simulated RT's. Different RT response time can be defined in the error description words.
- LSB = 1µs
- For some modes, this global RT response time register is not programmable (fixed at 4µs);
 - 3838Mode without data
- If the value is less than 4, the on-board processor selects 4µS.

3.4.2.23 RT No Response Time-Out Register (2AH)

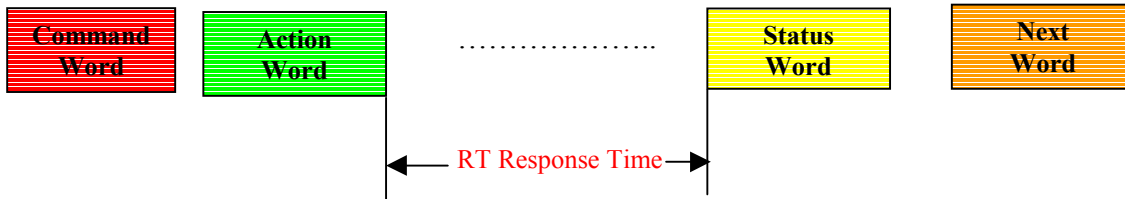

- The programmable RT no response time-out defines the maximum RT response time allowed by the board to an RT before detecting "NO RESPONSE".
- LSB = 1 us.

3.4.2.24 HS Sub Address (2CH)

Indication for the on-board processor of the sub-address value used to define HS messages.
 Set to 0x001A for EFA
 Set to 0x0001 for RAFALE.
 Set to 0xFFFF for 3838 operation only.

3.4.2.25 IRQ Selection Register (34H)

D15	D14	D13	D12	D11	D10	D09	D08	D07	D06	D05	D04	D03	D02	D01	D00
0	0	0	0			Cycling			Message			HI Queue			LO Queue
				0	0	C	0	0	M	0	0	H	0	0	L

C = If set, a physical INTA interrupt will be generated when a 'Broadcast Synchronise With Data' mode code occurs.

M = If set, a physical INTA interrupt will be generated when a push to the Message Queue occurs

H = If set, a physical INTA interrupt will be generated when a push to the High Priority Queue occurs

L = If set, a physical INTA interrupt will be generated when a push to the Low Priority Queue occurs

3.4.2.26 Test and Set Register and SRQADP (3CH)

These two words are used to automatically manage FIFO's of vector words for each simulated RT. For simulated RTs the "Service Request bit" in the status word can be set and reset by the user. The vector word can be initialised by the user.

After a "Transmit Vector Word" mode command message, the on-board processor automatically resets the service request bit and the vector word.

On the other hand a service request queue is defined to automatically queue words representing (successive) requests for the simulated RTs. This service request queue is 3 words long starting at the initial address in the service request queue address pointer (SRQADP).

For a request, two words are set in the queue as follows:

1. RT number: 00000000RRRRRIX
R = RT address, X = Priority, BIT 1 = 1.

2. Vector word

Two different priorities are available:

X = 0 High priority

X = 1 Low priority

Reading this FIFO, the on-board processor manages each RT two 32-word vector words FIFO's (one per priority). These vector words are then used by the RT simulation. If an RT FIFO is not empty, the on-board processor reads it, then writes the value in RT vector words (RT Simulation Table) and sets the service request bit in the status word.

If a "Transmit Vector Word" mode command message occurs, the on-board processor reads the RT FIFO's

- If empty the on-board processor resets the service request bit and the vector word.
- Otherwise the on-board processor reads the FIFO's and writes this next value in the RT vector word.

High priority vector words are processed before low priority vector words.

The following 4Kbyte block after the service request queue is reserved for the individual RT requesting FIFO's managed by the on-board processor:

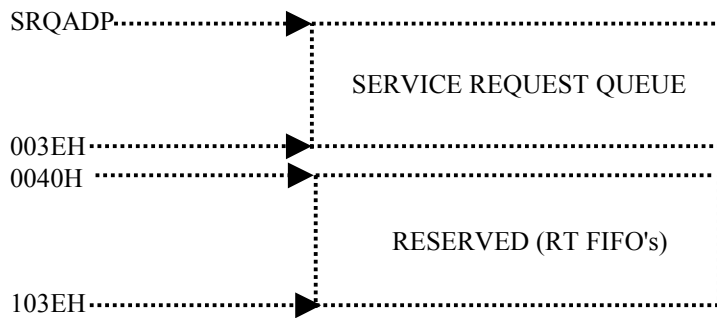

To enter a request in the User Requesting Queue, the user must manage the current writing pointer (SRQADP in Base Registers) and control the words pointed at are clear, if these words are non-zero, the queue is full. Reaching the end of the queue the user must restart at the beginning of the queue.

If several user CPUs can enter requests at the same time, it is necessary to share control of SRQADP, using for example the TASR flag with a test and set instruction. To enter a request a CPU must carry out the following procedure:

Test and set the TASR word (MSB bit) and:

- a)
 - If free, the SRQADP is read to define the entry address in the queue.
 - If the entry location defined by the SRQADP are clear the two words may be entered in the queue. If these words are non-zero, the queue is full.
 - Increments the SRQADP (if the end is reached, reinitialise it to the beginning).
 - Resets the TASR.
- b)
 - If not free, waits until free.

3.4.2.27 Reserved (46H)

3.4.2.28 PRI/SEC 3838/3910 RT TX Inhibit HI-LO (48H – 56H)

HI :		RT 30	RT17	RT16
LO :	RT15	RT14			RT1	RT0

- =0: enable the transmitter
=1: disable the transmitter
- A bit set defines the specific RT transmitter as inhibited.
- Initialisation by the user (before cold start).
- Disable/enable by corresponding mode command messages.
- The user can modify the inhibit bits in real time.
- The receive function of the simulated RT is never disabled.

3.5 REMOTE TERMINAL SIMULATION TABLE

For each RT 16 words are used to define and store information concerning RTs. The pointer to this table (RTSTAD) must be a multiple of 20H. Refer to table 4-4.

RT0	RTSTAD →	+00H	Simulation Type word
		+02H	RT Status Word
		+04H	LS Last Command Word
		+06H	LS Look-up Table Address (MRT Only)
		+08H	HS Look-up Table Address (MRT Only)
		+0AH	LS Mode Commands Look-up table Address (MRT Only)
		+0CH	Vector Word
		+0EH	LS BIT Word
		+10H	HS Status Word
		+12H	HS Last Action Word
		+14H	HS BIT Word
		+16H	Global RT Error Descriptor Word (MRT Only)
		+18H	Not Used
		+1AH	Not Used
		+1CH	Not Used
		+1EH	Not Used
RT1		+20H	
		+40H	
RT30		+3C0H	
	RT31 (Broadcast)	+3E0H	Only 3 words used Set all others to 0
		Broadcast LS Look-up Table	
		Broadcast HS Look-up Table	
		Broadcast LS Mode Commands Look-up Table Address	

Table 3-4 Remote Terminal Simulation Table

3.5.1 Simulation Type Word

	BIT 15 :	1 = RT simulated
Bits	BIT 14 :	1 = Reserved
14 to 0	BIT 13 :	1 = Inhibit transmitter LS on primary bus
are for	BIT 12 :	1 = Inhibit transmitter LS on secondary bus
MRT	BIT 7 :	1 = Errors enabled on primary bus (status word and data)
only	BIT 6 :	1 = Errors enabled on secondary bus (Status word and data)
	BIT 0 :	1 = Enable global error injection
	other bits:	0
	Bits 7 and 6	Enable global RT errors (defined in the RT simulation table) as message-per-message errors (defined in the look-up-tables).

3.5.2 Status Word

Broadcast and message error bits are dynamically updated. Service request bit automatically set by the request files and cleared by the TX vector word mode code command. Busy bit can be set by user to disable data transmission.

3.5.3 LS Last Command Word

Automatically updated (including broadcast), so the TX last command mode code is correctly simulated.

3.5.4 LS Bit Word

For user purposes.

3.5.5 HS Status Word

Automatically updated for frame error, RX ready/busy, TX ready/busy bits (including broadcast). So the 3910 TX command is correctly simulated. This word in the simulation table is used by the "on-board" processor as a flag to record FRAME errors. However, the user can force a HS Status word with the FRAME bit set, by writing a non zero value into this location.

3.5.6 HS Last Action

Automatically updated (including broadcast). So the 3910 TX command is correctly simulated.

3.5.7 HS Bit Word

For user purposes.

NOTES:

1. 3838 Mode Commands - TX shutdown and override TX shutdown are fully simulated. The status of the transmitters are available to the user in the Base Registers.
2. 3910 Mode Commands - TX shutdown and override TX shutdown are fully simulated. The status of the transmitters are available to the user in the Base Registers.
3. The user can modify the RTs simulation state in real-time.

4 BUS CONTROLLER MODE OF OPERATION

4.1 INTRODUCTION

In the Bus Controller mode the Western Avionics 4220 board runs a list of instruction pointed to by the Background Running Pointer defining the bus frame. Each bus message is defined by a Message Descriptor Block (MDB) and the associated data is accessed through a Look-Up Table (LUT) and Data Descriptor Blocks (DDB) the same way as in the Multi-Remote mode. Remote Terminals can simultaneously be simulated. All non-simulated data buffers can be monitored. An internal minor frame duration counter allows autonomous control of cycling frames. Acrylic messages can be inserted on the host request. Insertion instruction lists define sequences of messages to be inserted. Refer to figure 4-1 the Bus Controller Organisation Diagram.

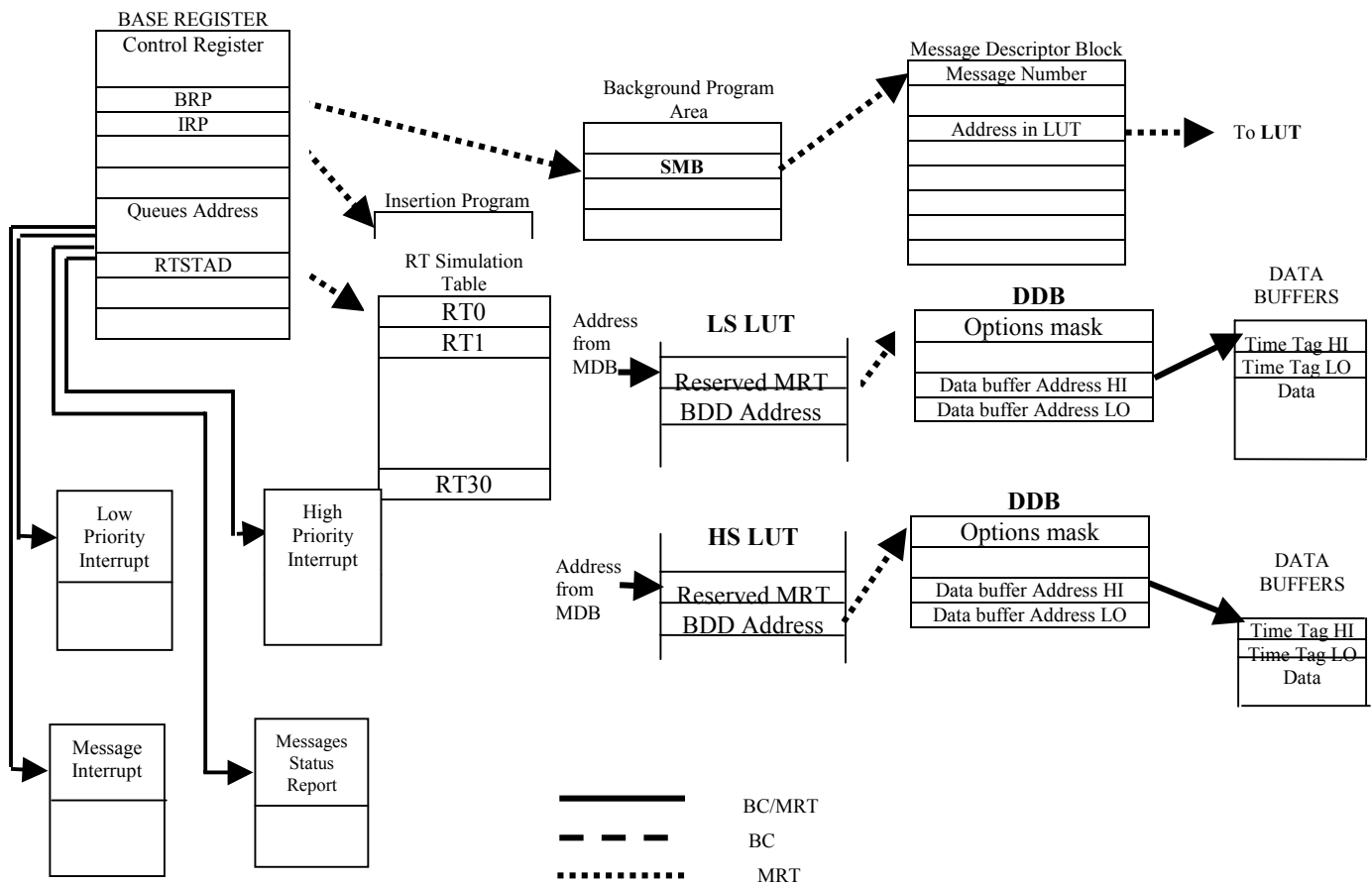

Figure 4-1 Bus Controller Organisation Diagram

4.2 MESSAGE DESCRIPTOR BLOCK (MDB)

Each bus message is defined by a message descriptor block as shown in table 4-1.

Table 4-1 Message Descriptor Block

MBD ADDRESS	MESSAGE NUMBER
+02H	LS Event Mask
+04H	Message Type Word
+06H	LS Message Error Phase Definition
+08H	LS Message Error Description Word
+0AH	Address in Look-up Table
+0CH	Command Word 1
+0EH	Command Word 2
+10H	Action Word 1
+12H	Action Word 2
+14H	Retry Subroutine Absolute Address
+16H	HS event Mask HS Overlap
+18H	Inter-message Gap Time
+1AH	HS RT-RT Inter-message Gap Time
+1CH	Status Word 1 (received)
+1EH	Status Word 2 for RT-RT (received)

4.2.1 Message Number (00H)

The number of the message is used in Message Status Report to identify messages.

4.2.2 LS Event Mask (02H)

A logical AND is carried out with the LS event mask and the detected bus events. If the result is $\neq 0$ a message status report will occur and a retry if selected.

BIT 15	:	Wrong/Both bus error
BIT 14	:	No response error
BIT 13	:	RT address error
BIT 12	:	Transmission error
BIT 11	:	Wrong sync error
Bit 10 to 00	:	Status bits of RX status word (not including address bits)

NOTE: Transmission error includes: Manchester error, Long or Short word error, Parity error, Word Count error and Late-Response error.

4.2.3 Message Type Word (04H)

BIT 15	:	1	=	3838 TX on PRI bus	
BIT 14	:	1	=	3838 TX on SEC bus	
BIT 13	:	0			
BIT 12	:	0			
BIT 11 to 8:					
		<u>11</u>	<u>10</u>	<u>09</u>	<u>08</u>
		0	0	0	0
					3838 MODE WITHOUT DATA
		0	0	0	1
					3838 MODE WITH DATA
		0	0	1	0
					3838 RT-RT
		0	0	1	1
					3838 BC-RT/RT-BC
		0	1	0	0
					3910 BC-RT
		0	1	0	1
					3910 RT-BC
		0	1	1	0
					3910 RT-RT
		0	1	1	1
					3910 TX MESSAGE/MODE CODE
		0	0	0	0
					3838 MODE WITHOUT DATA
					(BROADCAST)
		1	0	0	1
					3838 MODE WITH DATA
					(BROADCAST)
		1	0	1	0
					3838 RT-RT
					(BROADCAST)
		1	0	1	1
					3838 BC-RT
					(BROADCAST)
		1	1	0	0
					3910 BC-RT
					(BROADCAST)
		1	1	0	1
					RECEIVE CLOCK
					(BROADCAST)
		1	1	1	0
					3910 RT-RT
					(BROADCAST)
		1	1	1	1
					3910 MODE COMMAND
					(BROADCAST)
BIT 07	:	1	=	Extended Subaddress	
BIT 06	:	1	=	Retry on EVENT	
BIT 05	:	1	=	Interrupt on EVENT enabled	
BIT 04	:	1	=	Interrupt on EVENT HI priority queue, 0 = LO priority	
BIT 03	:	0	=	3910 Bus A, 1 = 3910 Bus B	
BIT 02	:	0			
BIT 01	:	0			
BIT 00	:	0			

- NOTES:**
1. If RETRY is enabled and IRQ on EVENT is disabled the RETRY will still take place.
 2. Broadcast Receive Clock is a special message used for transmitting the 32-bit clock as data. This message type only requires an MBD to define the command word and the inter-message gap. No queue, interrupt or buffer control is carried out. The transmitted message will be the command word defined by the MDB followed by two data words, Clock Value HI and Clock Value LO (clock value at the end message on the bus).
 3. The transmission of a Broadcast Synchronise with Data mode code using the 3838 mode with data broadcast message type will cause cycling interrupt to be generated (if enabled) and the associated data word defined in the data buffer will be stored in the cycling interrupt base register (40H).

4.2.4 LS Message Error Phase Definition (06H)

The following word defines the location of errors that can be injected into the LS message.

D15	D14	D13	D12	D11	D10	D09	D08	D07	D06	D05	D04	D03	D02	D01	D00
0	0	0	0	0	0	0	0	0	0	0	0	0	X	X	X

- XXX = 000 => Error Injection Disabled
- XXX = 001 => Inject Error in 1st BC TX (Initial BC message)
- XXX = 011 => Inject Error in 1st RT SIM (1st RT response)
- XXX = 100 => Inject Error on 2nd RT SIM (2nd RT-RT response)

4.2.5 LS Message Error Description Word (08H)

The following word defines the errors that can be injected into the 3838 message.

D15	D14	D13	D12	D11	D10	D09	D08	D07	D06	D05	D04	D03	D02	D01	D00
T	T	T	X	X	X	X	X	X	X	X	X	X	X	X	X

TTT = 000 => Modulation Error

XXXXXXXXXXXXXXXX = WWWWWYYYYYYYY

WWWWWW = Word Number For Modulation Error

Y	Y	Y	Y	Y	Y	Y		=	ERROR TYPE
0	0	0	0	0	0	0		=	Parity error
0	S5	S4	S3	S2	S1	S0		=	Synchro Pattern Error
1	0	B4	B3	B2	B1	B0		=	Manchester Bit Error
1	1	L4	L3	L2	L1	L0		=	Word Length Error

TTT = 001 => Wrong Bus Error

XXXXXXXXXXXXXXXX = 000000000000

TTT = 010 => Both Bus Error

XXXXXXXXXXXXXXXX = 000000000000

TTT = 011 => Word Count Error

XXXXXXXXXXXXXXXX = 00000PCCCCC

P = Word Count Error Polarity

0 = Word Count Error +VE

1 = Word Count Error -VE

CCCCC = Word Count Error Value (Allows +/- 64 Words)

TTT = 100 => Response Time Error

XXXXXXXXXXXXXXXX = 0000000RRRRR

RRRR = Unique Response Time for simulated RT in uS.

TTT = 101 => Illegal Command

(Not applicable for BC Mode)

XXXXXXXXXXXXXXXX = 000000000000

TTT = 110 => Extended Subaddress

(Not applicable for BC Mode)

XXXXXXXXXXXXXXXX = 000000000000

TTT = 111 => Resync. System Clock

(Not applicable for BC Mode)

XXXXXXXXXXXXXXXX = 000000000000

- NOTES:**
1. Word Number : For the first word of the message (command or status) WWWWWW = 000000.
 2. Synchro Pattern Error : Defines a specific synchro bit, each Si defines the level for 500ns duration (at least 1 bit of S5 - S0 must be set).

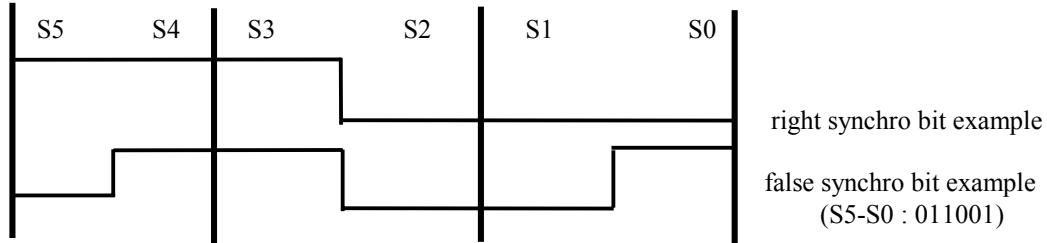

3. Manchester Bit Error : B4-B0 defines the bit position in the word for the error
4. Word Length Error : L4-L0 defines the number of bits in the word.

NOTE: This count has an offset of 1 such that a value of 01111 will result on a valid word with a data bit count of 16.

- Wrong bus error : RT response on the wrong bus
- Both busses error : RT response on both busses
- Response time error : RRRRRR replaces the global RT response time (LSB = 1 uS)
- Illegal command : Reserved for MRT only

4.2.6 Address in Look-Up Table (0AH)

This will contain the address in the look-up table for the DDB pointer. (See figure 4-1).

4.2.7 Command Word 1 (0CH)

First Command Word.

4.2.8 Command Word 2 (0EH)

Second Command Word (RT-RT 3838).

4.2.9 Action Word 1 (10H)

First Action Word to be transmitted (3910 message).

4.2.10 Action Word 2 (12H)

Second Action Word to be transmitted (RT-RT 3910)

4.2.11 Retry Subroutine Absolute Address (14H)

On completion of a message, if an Event defined by the Mask has occurred and the Retry Event is enabled, the Subroutine defined by this absolute address will be called.

- NOTES**
1. The retry subroutine must be terminated by the RTS instruction to return execution back to the main background or insertion program.
 2. This feature can be used for immediate insertion of Acyclic messages or retry of the same message on the alternate bus.

3. HS Event Mask (16H)

BIT 15 to 07	:	0
BIT 06	:	HS Data Overlap Error
BIT 05	:	3910 Word Count Error
BIT 04	:	FCS Error
BIT 03	:	Invalid/No End Delimiter
BIT 02	:	Invalid/NO Start Delimiter
BIT 01	:	3910 No Response
BIT 00	:	3910 Frame Word Timeout

NOTE: HS Data Overlap error bit : Indicates that the HS data words of the previous message have been overlapped by the HS data words of the new image.

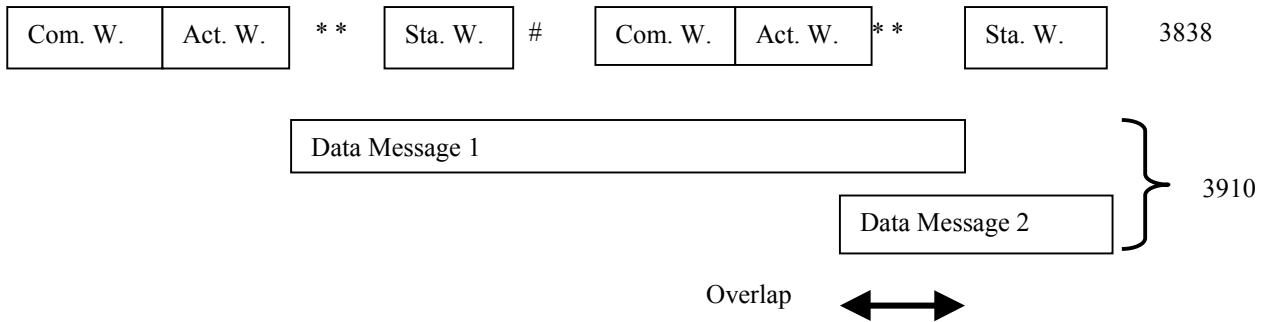

4.2.12 Inter-message Gap Time (18H)

- Gap between the end of this message and the LS line and the beginning of the next one (next MDB).
- LSB = 0.1 uS.
- For 3910 message this inter-message gap time must take account of the HS message.

4.2.13 HS RT-RT Inter-message Gap Time (IAH)

- Gap between the two 3838 messages initiating a HS RT-RT message.
- LSB = 1µs.

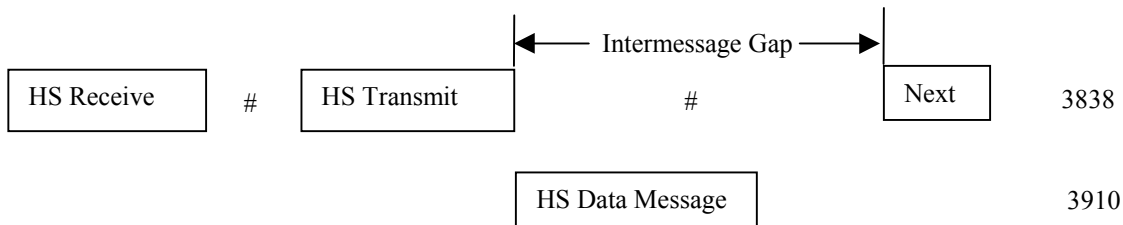

4.2.14 Status Word 1 (ICH)

First RX Status Word in the message. If the BC detects no response error, this value will be updated with FFFFH.

4.2.15 Status Word 2 (IEH)

Second RX Status Word in the message (RT-RT). If the BC detects a no response error from the second RT, this value will be updated with FFFFH.

4.3 DATA BUFFERS SIMULATION AND MONITORING

The Western Avionics 4220 board processes all the data buffers running on the LS and HS lines. Data buffers to be issued by the BC or the simulated RTs are transmitted by the 4220 board, all others can be monitored. A multiple data buffering structure is implemented. Identical paths are used to access the data buffers, whether they are transmitted, received, LS or HS. These paths use a look-up-table and data descriptor block. Refer to figure 4-2 Data Buffers Simulation and Monitoring.

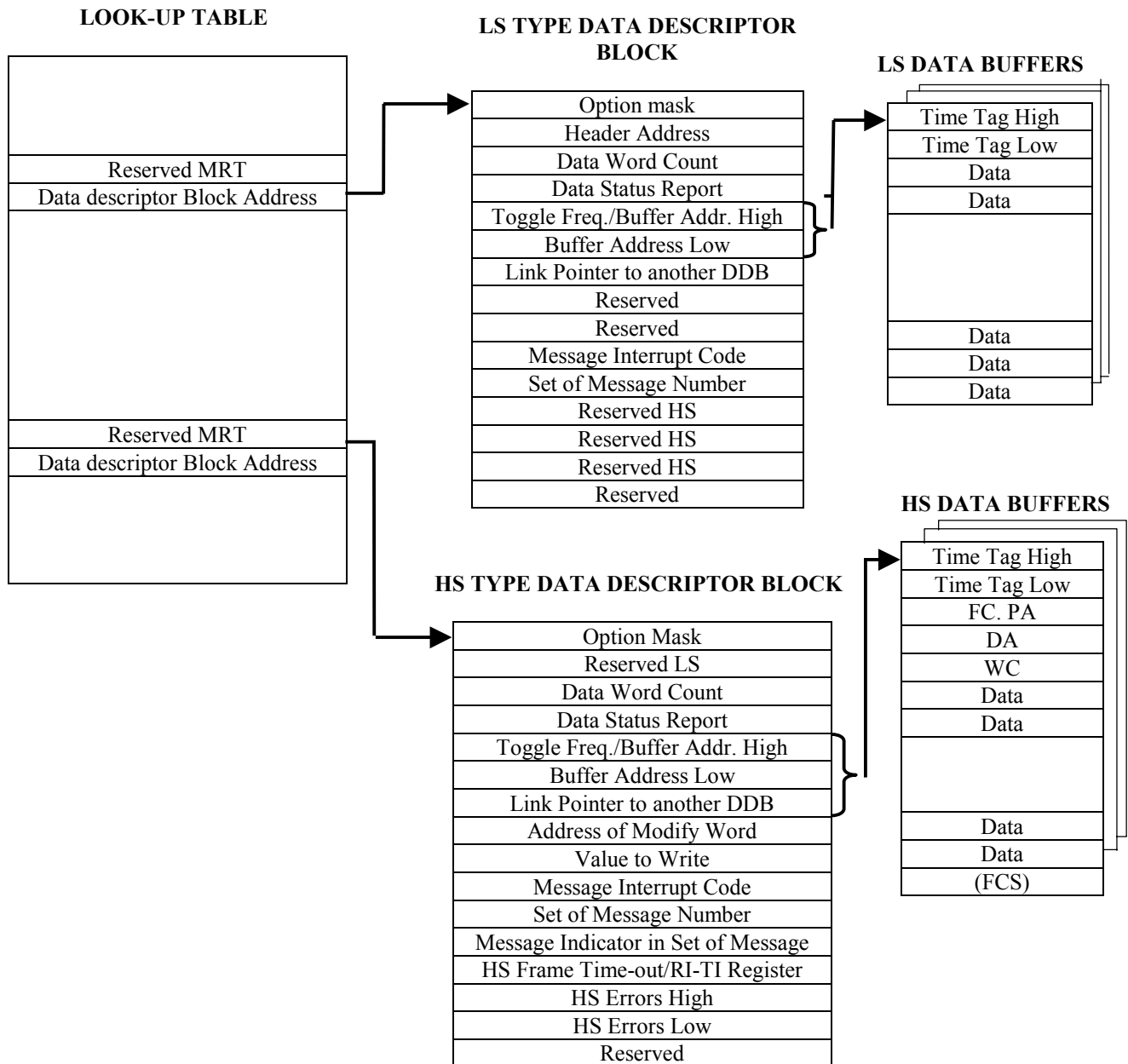

Figure 4-2 Data Buffers Simulation and Monitoring

4.3.1 Look-Up-Table

The sixth word of a message descriptor block points to a double word in the look-up-table, that one contains the address of a LS or HS data descriptor block. An identical architecture is defined in MRT mode, but using LS sub-addresses or HS message identifiers to point into the look-up-table.

Look-up Table Address : Error Injection Word (MRT only).
 02H : DDB Address/Ext-Subaddress look-up table address.

4.3.2 Data Descriptor Block

A data descriptor block is associated with each data message, this 16-word set defines the data buffering and associated queue control information. Interrupt selection is defined in the option mask word. Interrupt on correct or erroneous message, or after a set of different messages and priority of interrupt (three different available, one interrupt only per message).

The data word count contains the data word count expected by the user. The Western Avionics 4220 processor compares this word count with real data word count transmitted on the bus and writes the difference if any in the data status report word. This last word also contains the status flag of the transmission, message received correct or with error, message running. The most significant byte of data buffer address can be used to enable toggled buffer control; toggle on beginning of each minor frame or on multiple cycles of this minor frame. This allows user software synchronised on the frame cycle to always access the correct buffer. The set of message interrupt features provides the possibility to send an interrupt after the last message of the set of messages. It is to be used when the frame sequence is not purely repetitive. Up to 128 different sets of messages from 2 to 16 messages each can be defined. Refer to table 4-2.

A HS type data descriptor block also defines HS transmission characteristics:

- HS frame time-out (LSB = 100 nS), RI or TI values (LSB = 1µs).
- HS error injection (no response, preamble bit count error, word count error, FCS error, Bit encoding error, Bit count error, start/end delimiter pattern error).

Error injection on LS data words is defined in the message descriptor blocks.

Table 4-2 Data Descriptor Block

DDB ADDRESS	OPTION MASK
+02H	Header Address
+04H	Data Word Count
+06H	Data Status Report
+08H	Toggle Frequency and Buffer Address HI
+0AH	Buffer Address LO
+0CH	Link Pointer to Address of another DDB
+0EH	Address of Modify Word
+10H	Value to Write
+12H	Message Interrupt Code
+14H	Set of Message Number
+16H	Message Indicator in the Set of Messages
+18H	RT-TI Time Register
+1AH	3910 Error Injection 1
+1CH	3910 Error Injection 2
+1EH	3910 Error Injection 3

4.3.2.1 Option Mask (00H)

BIT 15	1 = Interrupt on Correct Message
BIT 14	1 = Interrupt on Error Message
BIT 13	1 = HI/LO Priority Queue (0 = LO, 1 = HI)
BIT 12	1 = Interrupt on Set of Messages
BIT 11	1 = Message Interrupt (If Message Correct)
BIT 10	1 = Link only on Correct Message
BIT 09	1 = Link to New DDB Enabled
BIT 08	1 = Modify Word Enabled
BIT 07	0
BIT 06	0
BIT 05	0
BIT 04 to 00	Header Word Count

4.3.2.2 Data Status Report (06H)

BIT 15 to 14	00 = Good Message 01 = Message Running 10 = Error Message
BIT 13 to 00	Signed Wordcount Error. 0 = No Wordcount Error

NOTE: The wordcount error is calculated as follows:

3838 TX Wordcount = Command Wordcount - (DDB Count + Header Count)
3838 RX Wordcount = Wordcount Received - (DDB Count + Header Count)
3910 TX Wordcount = Action Wordcount - DDB Count
3910 RX Wordcount = Action Wordcount - DDB Count

4.3.2.3 Toggle Frequency and Buffer Address HI (08H)

The word +24H in Base Registers defines if the data buffer toggle feature is enabled and also the toggle offset:

- MSB: 1= global toggle enabled, 0 = no toggle.
- offset: 15 bits

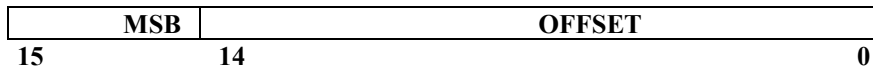

The 5th word in a DDB enables the toggle feature for the corresponding data buffer and the toggle frequency:

BIT 15	1 = Enable toggle (local)
BIT 14 to 11	0
BIT 10 to 08	Frequency indicator => 000 = FHz, 001 = F/2Hz, 011 = F/4Hz, 111 = F/8Hz
BIT 07 to 00	Buffer Address HI

When global toggle is enabled, for a data buffer if the toggle feature is selected (bit 15 = 1) the address of the toggle buffer is:

(Buffer Address High + Toggle Buffer Offset (15 bits)), Buffer Address Low.

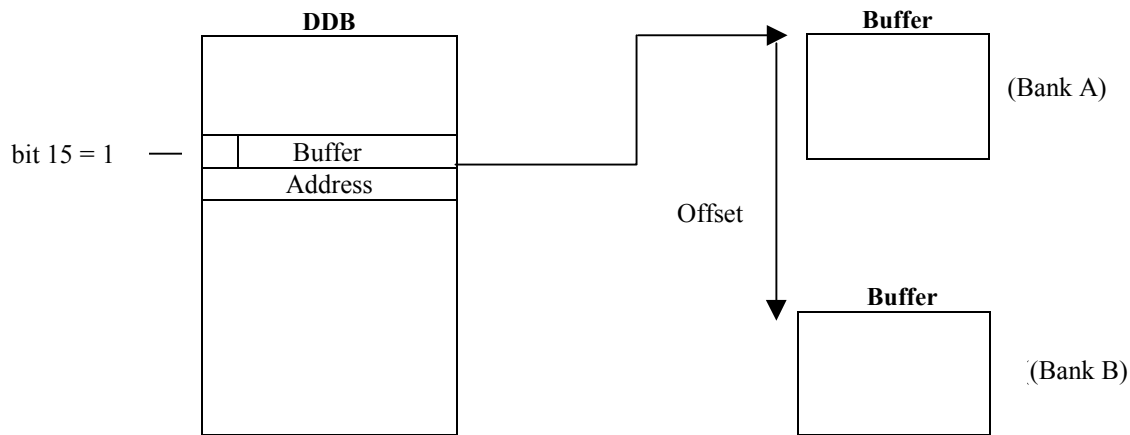

The toggle is synchronised on the minor frame counter register, which is incremented on each minor cycle restart.

The on-board processor stores the data buffer in bank A or B depending on the number of the running minor cycle and the frequency indicator of the message.

Minor Cycle (frequency F)	0	1	2	3	4	5	6	7	8	9	A	B	C	...
F Hz.	A	B	A	B	A	B	A	B	A	B	A	B	A	
F/2 Hz	A	A	B	B	A	A	B	B	B	A	B	B	A	
F/4 Hz	A	A	A	A	B	B	B	B	A	A	A	A	B	
F/8 Hz	A	A	A	A	A	A	A	A	B	B	B	B	B	

4.3.2.4 Link Pointer to New DDB (0CH)

If the message is good or bit 10 of the option mask is clear and bit 9 of the option mask is set the value in this location will replace the original DDB address in the look-up table. This feature defines a different DDB for the next occurrence of the same message.

4.3.2.5 Address of Modify Word/Value to Write (0EH-10H)

After the message is complete and bit 8 of the option mask is set the Value to Write is written in the address defined by the contents of 0EH. (Action is limited to the first 64Kbytes of the memory).

4.3.2.6 3910 Frame Timeout and RI / TI Time Register (18H)

- BIT 15 to 13: Set to 0.
- BIT 12: If this bit is set, the HS data stream will have a +ve word count error.
- BIT 11: If this bit is set, the HS data stream will have a -ve word count error.
- BIT 10: If this bit is set, the HS data stream will not be transmitted (HS no response).
- BIT 09 to 08: Set to 0.
- BIT 07 to 00: TI time for 3910 TX => time for 3910 data to start from end of BC action word.
LSB = 1uS.
RI time for 3910 RX => time for RX timeout after end of BC action word.
LSB = 1us.

4.3.2.7 3910 Errors Injection 1(1AH)

This word defines the desired start and end delimiter patterns for transmissions as follows:

D15	D14	D13	D12	D11	D10	D09	D08	D07	D06	D05	D04	D03	D02	D01	D00
ED7	ED6	ED5	ED4	ED3	ED2	ED1	ED0	SD7	SD6	SD5	SD4	SD3	SD2	SD1	SD0

SD7-0 defines the start delimiter pattern. Each bit is a 50nS segment of the start delimiter starting with SD7 and ending with SD0.

ED7-0 defines the end delimiter pattern. Each bit is a 50nS segment of the end delimiter starting with ED7 and ending with ED0.



As can be seen above, for a good start and end delimiter this register should be set to:

$$1000111001110001 = 0x8E71.$$

Any other value will inject start/end delimiter pattern errors.

4.3.2.8 3910 Errors Injection 2(1CH)

This word defines further error injection features as follows:

D15	D14	D13	D12	D11	D10	D09	D08	D07	D06	D05	D04	D03	D02	D01	D00
0	0	PR5	PR4	PR3	PR2	PR1	PR0	BT3	BT2	BT1	BT0	FCS	ML	ME	MM

PR5-0: The value of this defines the number of preamble bits to transmit (1-63).

BT3-0: The value if this defines the bit count error for the HS data stream.

Values 0001-1111 define the number of bits to remove from the data stream.

Hence, 1111 will result in the data stream being short by 15 bits.

For no bit error this value should be set to 0000.

FCS: If this bit is set, an FCS error will be injected into the data stream (the FCS word will be incorrect).

ML: If a Manchester encoding error is required in the data stream this bit will define the level for the bit.

ME: If this bit is set, a Manchester error will be injected into the data stream of level ML.

MM: The position of the Manchester error is defined by a 17 bit count. This bit is the MSB of this count.

The remainder of the count is defined in the following register.

4.3.2.9 3910 Errors Injection 3(1EH)

This word is the remaining 16 bits of the Manchester error injection bit position in the data stream.

4.3.2.10 Extended Sub-Address

To enable the extended sub-address feature see the MDB type word. When enabled the value of the DDB address in the look-up-table is in fact a pointer for a further look-up-table called the extended look-up-table. The on-board processor uses the 3838 byte of the first data word received (multiplied by four) to calculate an offset in the extended look-up-table to find the true DDB address word. Therefore, the DDB and data buffer used is defined by the value of the first 3838 RX data word.

+ Offset: Reserved MRT
 +02H: DDB address

4.3.3 Data Buffers

Data buffers are pointed to by the buffer address word contained in the data descriptor blocks. The address of the toggled buffer is calculated by adding the global toggle offset to the data buffer address value in the DDB. The first two words of a data buffer are updated with the value of the local clock at the beginning of the message.

HS data buffers contain:

- The Time Tag.
- The three protocol words of the HS frame (FC/PA, DA, WC).
- The HS data words.
- The frame check sequence (FCS) for received data buffers.

For transmitting data buffers, the FC and PA bytes are automatically updated by the micro-controller.

LS data buffers can be stored as follows:

- The standard way - data words behind the time-tag words.
- A particular way allowing the user to store header words of the data message in a different buffer from the following data words.

The header option and the number of header words are defined in the option mask.

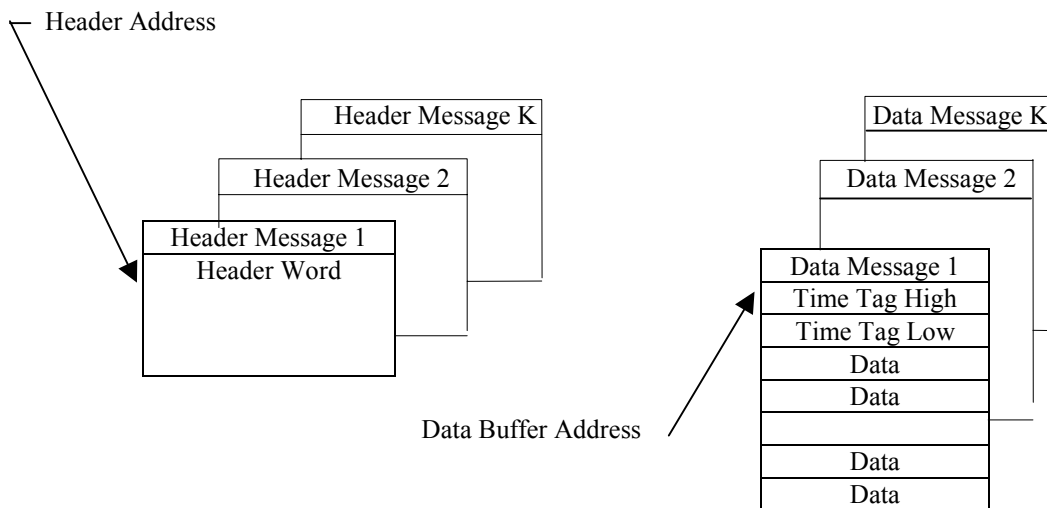

DB ADDRESS	3838 BUFFER	3910 BUFFER
+00H	Time Tag HI	Time Tag 3
+02H	Time Tag LO	Time Tag 4
+04H	Data	FC, PA (Automatically Updated)
+06H	Data	DA
+08H	Data	WC
+0AH	Data	Data
+0CH	"	Data
"	"	"
"	with or without	"
	Header Word	"
	"	Data
	"	Data
	"	FCS (In Receive Message only)

Table 4-3 Data Buffers

4.4 MODE COMMANDS

In Bus Controller mode the Western Avionics 4220 board can transmit all mode command messages (LS or HS). For each mode command message, data descriptor blocks pointed through the look-up table allow the definition of interrupt requests or associated data word address storage. If such a command is directed to an on-board simulated RT, the corresponding actions are made on the RT simulation table:

- Transmit - RT status word, last command word, LS bit word.
- Inhibit or override inhibit LS or HS transmitters.

Examples:

a) Synchronise with Data Word:

- The data is obtained from the data buffer pointed by the DDB.

b) Transmit Last Command:

- A DDB is analysed; the data word transmitted is stored in the data buffer. If the RT is simulated, the last command word from the RT simulation table is transmitted.

c) Transmit Bit Word:

- Similar to transmit last command.

d) Transmit Vector Word:

- Similar the transmit last command, and then if the RT is simulated, the service request bit in the RT status word is reset and the vector word is reset or updated with the next vector word in FIFO's, if any.

4.5 INTERRUPT REQUESTS

Three types of interrupt requests (IRQ) can be generated by the Western Avionics 4220 board:

- IRQ-L and IRQ-H (low priority and high priority) are synchronisation interrupts, defined as follows:
 - By instructions in the BC instruction list.
 - In message descriptor block to report on bus events detection.
 - In data descriptor block to signal the transmission of a message.
- IRQ-M is a data message interrupt and occurs only when the transmission of a data buffer is correct and the requesting bit is set in the data descriptor block. It can also be programmed to occur with the last message of a set of 2 to 16 messages (set of messages option).

When setting an IRQ the Western Avionics 4220 board pushes a vector code into queues, each code defines the event origin of the IRQ.

Each queue must start at an address multiple of 200H. The user must manage the reading pointer, and erase with a 0000H value, the codes after reading.

4.5.1 Interrupt Coding

1. LO and HI priority interrupts (two words):

Messages without error :	0800H, DDB Address
Messages with error :	0C00H, DDB Address BC
Event without RETRY :	1000H, Status Queue Address
BC Event with RETRY :	4000H, Status Queue Address
Send Interrupt (SITL/SITH) :	2000H, SITL/SITH Vector

2. Message Interrupts (one word):

Message Interrupt Code from DDB (Only if Message is Good)

4.5.2 Set Message Interrupts

When in a DDB, bit 12 of the option mask word is set:

- The 10th word gives a set of message numbers (00H to FFH).
- The 12th word gives a message indicator.
- For each set, the on-board processor manages a set word register;
 - It makes an "OR" with the message indicator in the set word register.
 - Then if the set word register is equal to FFFFH, the on-board processor sends a message interrupt code defined in the 9th word of the DDB, and resets the set word register.
 - It is possible to define sets from 2 to 16 messages.
 - The user initialises at 0 the set of messages table.

The 256 word set of messages table is pointed to by the set of Messages Start Address (26H in Base registers).

4.5.3 Message Status Report Queue

At the end of a message, if an event is detected and matches with the 3838 or 3910 Event Masks of the MDB, a Message Status Report is pushed in to the Message Status Report queue (2 words per report).

1. 3838 Messages:

Message Number (MSB = 0), EVENTS with EVENTS:

BIT 15	:	Wrong/Both Buses Error
BIT 14	:	NO RESPONSE Error
BIT 13	:	RT ADDRESS Error
BIT 12	:	TX Error- Mn, LG, SH, Py, WC, Late-Response
BIT 11	:	SYNC Type Error
Bit 09	:	0 = 1st Status, 1 = 2nd Status
BIT 10, BITS 08 to 00	:	RX Status Bits

2. 3910 Messages:

Message Number (MSB = 1), EVENTS with EVENTS:

BIT 15 to 08	:	0
BIT 07	:	HS Data Overlap Error
BIT 06	:	HS wordcount error polarity (1 = Too many words).
BIT 05	:	HS Word Count Error
BIT 04	:	HS FCS Error
BIT 03	:	HS preamble count error
BIT 02	:	HS Manchester encoding error
BIT 01	:	HS RI timeout
BIT 00	:	HS Bit count error

5 MULTIPLE REMOTE TERMINAL MODE OF OPERATION

5.1 INTRODUCTION

In Multiple Remote Terminal mode the Western Avionics 4220 board can simulate up to 31 RTs. After initialisation by the host, the board is ready to listen to the bus activity and to respond to command words for the simulated RTs. The description of the mode of operation uses tables similar to those defining the bus controller mode, providing the same associated features (multiple data buffering, signalisation etc.). Refer to figure 5-1, the Multiple Remote Terminal Organisation Diagram.

The specifics of the MRT mode of operation mainly concern the following

- The logical path to point into the look-up-tables.
- The errors injection capabilities.

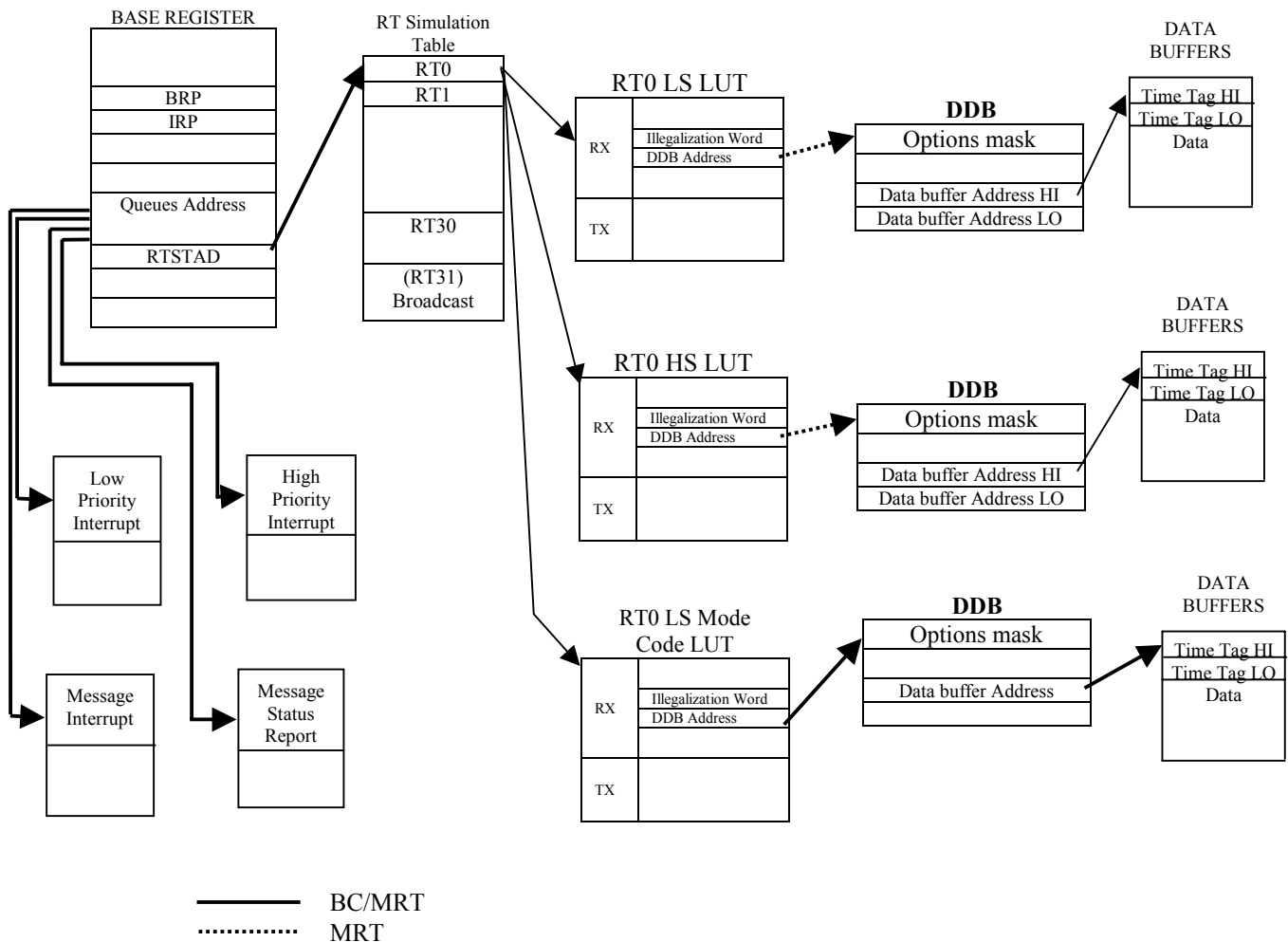

Figure 5-1 Multiple Remote Terminal Organisation Diagram

5.2 LOOK-UP-TABLES

For each RT the Western Avionics 4220 board manages three different look-up-tables, the address of these tables are obtained from the RT simulation tables. These tables are as follows:

- LS Look-up Table giving a descriptor for each LS sub-address.
- HS Look-up-Table giving a descriptor for each HS message identifier.
- LS Mode Command Look-up-Table giving a descriptor for each 3838 mode code.

NOTE: The T/R bit of the Command word or Action word is used as an offset to point to the RX or TX block of the look-up tables.

Each descriptor includes:

- A Message Error Description (or Illegalization) word.
- A Data Descriptor Block Address (or Extended sub-address look-up table address) as for BC mode.

5.3 MODE COMMANDS SPECIFICATIONS

All illegal mode codes defined in the 3838 standard are automatically illegalized. The error descriptor word allows illegalization of complementary mode codes.

Associated data words which are not obtained from the RT Simulation Tables can be obtained from (or stored in) memory using Data Descriptor Blocks. For each mode code DDB can be used to define IRQ's.

HS mode commands are processed in accordance with STANAG 3910. The message identifier points 00 (T/R=0) and 80H (T/R=1) in the HS look-up-table define two illegalization and DDB address word pairs for all HS mode commands. This allows one of the mode types (T/R=0 or T/R=1) to be illegalized if required. The DDB allows the definition of common interrupt requests for all the HS mode commands.

5.4 DATA WORDS STORAGE

To avoid data buffers overwriting in memory when receiving a data message, the 4220 board does not store more data words than the number defined by:

- Data Word Count + 1 (if no header option), or Data Word Count + Header Word Count + 1 (if header option).
- Data Word Count for HS message.

Data Word Count is defined in the DDB. The extra word for LS messages will be the last received word of a message in excess of the DDB data word count.

5.5 LS ERROR INJECTION DEFINITION

Error injection on status word and 3838 data words transmitted can be defined message by message using the message error descriptor word in the look-up-table, or globally for all messages transmitted by an RT using global RT error injection word in each RT simulation table.

5.5.1 Global RT Error Description Word (RT Simulation Table)

The following word defines the errors that can be injected into the message.

D15	D14	D13	D12	D11	D10	D09	D08	D07	D06	D05	D04	D03	D02	D01	D00
T	T	T	X	X	X	X	X	X	X	X	X	X	X	X	X

TTT = 000 => Modulation Error

XXXXXXXXXXXXXXXX = WWWWWYYYYYYY

WWWWWW = Word Number For Modulation Error

Y	Y	Y	Y	Y	Y	Y	Y	=	ERROR TYPE
0	0	0	0	0	0	0	0	=	Parity error
0	S5	S4	S3	S2	S1	S0		=	Synchro Pattern Error
1	0	B4	B3	B2	B1	B0		=	Manchester Bit Error
1	1	L4	L3	L2	L1	L0		=	Word Length Error

TTT = 001 => Wrong Bus Error

XXXXXXXXXXXXXXXX = 000000000000

TTT = 010 => Both Bus Error

XXXXXXXXXXXXXXXX = 000000000000

TTT = 011 => Word Count Error

XXXXXXXXXXXXXXXX = 000000PCCCCC

P	=	Word Count Error Polarity
2	=	Word Count Error +VE
3	=	Word Count Error -VE
CCCCC	=	Word Count Error Value (Allows +/- 64 Words)

TTT = 100 => Response Time Error

XXXXXXXXXXXXXXXX = 0000000RRRRR

RRRR = Unique Response Time for simulated RT in uS.
See NOTE (4) in paragraph 5-5.2

NOTE: Global error injection is enabled/disabled by the LSB bit of the simulation type word.

5.5.2 Message Error Injection Word (Look-up-Table)

The following word defines the errors that can be injected into the message.

D15	D14	D13	D12	D11	D10	D09	D08	D07	D06	D05	D04	D03	D02	D01	D00
T	T	T	X	X	X	X	X	X	X	X	X	0	X	X	X

TTT = 000 => Modulation Error

XXXXXXXXXXXXXXXX = WWWWWYYYYYYYY

WWWWW = Word Number For Modulation Error

0 : status word
1 : 1st data word

Y	Y	Y	Y	Y	Y	Y	Y	=	ERROR TYPE
0	0	0	0	0	0	0	0	=	Parity error
0	S5	S4	S3	S2	S1	S0		=	Synchro Pattern Error
1	0	B4	B3	B2	B1	B0		=	Manchester Bit Error
1	1	L4	L3	L2	L1	L0		=	Word Length Error

TTT = 001 => Wrong Bus Error

XXXXXXXXXXXXXXXX = 000000000000

TTT = 010 => Both Bus Error

XXXXXXXXXXXXXXXX = 000000000000

TTT = 011 => Word Count Error

XXXXXXXXXXXXXXXX = 000000PCCCCC

P = Word Count Error Polarity
0 = Word Count Error +VE
1 = Word Count Error -VE
CCCCC = Word Count Error Value (Allows +/- 64 Words)

TTT = 100 => Response Time Error

XXXXXXXXXXXXXXXX = 0000000RRRRR

RRRR = Unique Response Time for simulated RT in uS.
See NOTE (4) in paragraph 5-5.2

TTT = 101 => Illegal Command

XXXXXXXXXXXXXXXX = 000000000000

TTT = 110 => Extended Subaddress

XXXXXXXXXXXXXXXX = 000000000000

TTT = 111 => Resync. System Clock

XXXXXXXXXXXXXXXX = 000000000000

- NOTES:**
1. No error : TTT = 000, WWWWWW = 111111
 2. LS errors injection on HS action words commands:
The VXI-2800 module can inject errors on the LS status words in response to an action word receive command when simulating the RT. The error injection is defined in the look-up-table in the word pointed by the HS sub-address, so it is common for the HS message identifiers.
 3. In the HS look-up-table:
For an HS message identifier, the error description word can take only two values:

Word = 0000H for normal
Word ≠0000H to illegalize the corresponding HS message identifier.

Illegalization is managed (corresponding to the STANAG 3910) by the setting of the HS message frame error bit in the HS status word. If a HS TX message is illegalized the RT will not transmit the HD data.

Error injections on the HS lines are defined in the DDB.

4. TX mode codes and all HS messages have fixed response times and will not be affected by the global or look-up-table response time error option. All other messages have a minimum response time of 8 μ s. The individual response time facility in the error injection word is a value that is added to the minimum response time. Therefore, a unique response time value of three in the error word will result in of response time of 11 μ S.

5.6 INTERRUPTS CODING

5.6.1 Low and High Priority Interrupts (two word code)

On data messages without error	:	0800H, DDB address
On data messages with error	:	0C00H, DDB address
On mode commands without error	:	0900H, DDB address
On mode commands with error	:	0D00H, DDB address
On HS mode commands without error	:	0AXXH, Action word
On HS mode commands with error	:	0EXXH, Action word (XX = RT number)

5.6.2 Message Interrupts (or set of messages interrupt)

One word code equals message interrupt code in data descriptor block. The code is pushed in queue only if the message is correct. Sets of Messages: Same feature as for BC mode.

5.6.3 Status Report Queue (two words per report)

Code pushed into queue only if error on message and Interrupt on erroneous message not set in the DDB.

1st Word: Pointer to the double word in look-up-table (look-up-table address + index)

2nd Word: Events

BIT 15	:	Wrong/Both Buses Error
IT 14	:	No Response Error
IT 13	:	RT Address Error
IT 12	:	TX Error- Mn, Lg, Sh, Py, WC, Late-Response
BIT 11	:	SYNC Type Error
BIT 10 to 7:	:	Not Used
BIT 06	:	HS wordcount error polarity (1 = Too many words).
BIT 05	:	HS Word Count Error
BIT 04	:	HS FCS Error
BIT 03	:	HS preamble bit count error.
BIT 02	:	HS manchester encoding error
BIT 01	:	HS RI timeout
BIT 00	:	HS bit count error

The bits 15 to 11 are used for:

- Status Word and data if it's an LS message.
- Status Word if it's a transmitted HS message.

NOTE: If an error is detected on an action word (data following a receive command with HS sub-address) a report is pushed in the queue:

1st Word	:	Pointer to the LS look-up-table with index = HS sub-address
2nd Word	:	LS error code on bits 15 to 11.

5.7 SPECIFIC FUNCTIONS

5.7.1 Data Message Reception

Each data message not transmitted by the Western Avionics 4220 board may be stored. The path to access the data buffer is given by the RT look-up-table for messages BC \Leftrightarrow RT. Except for RT->RT messages, even if the RTs are simulated or not, the path to point to the data buffer is always given by the transmitting RT look-up-table, but the receiving RT look-up-table must point to a false DDB. Received status words from RTs not simulated on-board are stored in the associated disabled RT SIM table. If an external RT fails to respond a value of FFFFH will be stored in the SIM table.

5.7.2 Reception of Mode Commands Data Words

For each mode command with data word message, if the data word is not transmitted by the board, it must be stored (RT simulated or not). The path for storing the data word is given by the RT mode command look-up-table.

5.7.3 Mode Command "Synchronise with Data Word"

When receiving a broadcast mode command "Synchronise with Data word", the on-board processor:

- Stores the data word value in the "Cycling Interrupt Update Register" in base registers and set the cycling IRQ.
- Accesses to a DDB to store the data word in a buffer and time-tag the data buffer.
- Uses the value of the data word (which is for example the minor cycle number: 0 to 7) to manage frequency toggling of the data buffers.

5.7.4 Frequency Toggle

The frequency toggle option works in the same manner as the BC mode except that the minor cycle number is given by the data word associated to the mode command synchronise with data word. This mode command is due to circulate on the bus at the beginning of each minor cycle and toggles (bank A or B) are managed when this message occurs.

Minor Cycle (frequency F)	0	1	2	3	4	5	6	7	8	9	A	B	C	...
F Hz.	A	B	A	B	A	B	A	B	A	B	A	B	A	
F/2 Hz	A	A	B	B	A	A	B	B	B	A	B	B	A	
F/4 Hz	A	A	A	A	B	B	B	B	A	A	A	A	B	
F/8 Hz	A	A	A	A	A	A	A	A	B	B	B	B	B	

5.7.5 Programmable HS RI / TI Time in DDB

When in MRT mode these values have an offset of 18 μ s. For example, if the user requires a TI time of 30 μ s a value of 12 must be stored in the DDB word.

6 CHRONOLOGICAL BUS MONITOR MODE OF OPERATION

6.1 INTRODUCTION

When acting in BC or MRT mode, a comprehensive window monitor facility is provided. However, the Western Avionics 4220 can also act as a chronological monitor for bus event detection and message recording. In this mode the Western Avionics 4220 can be set to trigger on specific events, and sequentially record precise time stamped messages on a stack. The size and position of this stack can be defined by the user.

NOTE: When the Western Avionics 4220 is in this mode the BC/MRT facility is not available.

All address pointers for the Bus Monitor are 16 bit words defining a PAGE address. Each page is 32 bytes.

Example: If a message pointer contains the value 2301H this indicates an absolute address of $\text{BASE} + (2301\text{H} \times 20\text{H}) = \text{BASE} + 46020\text{H}$.

6.2 BASE REGISTERS

Table 6-1 Base Registers

BASE	REGISTER
+00H	Control Register (Write) / Clock HI Word (Read)
+02H	Clock LO Word (Read) LSB of clock = 0.5 uS.
+04H	Command Register (CR)
+06H	Status Register (SR)
+08H to +20H	Reserved
+22H	Transformer/Direct Coupling Select Register
+24H to +2AH	Reserved
+2CH	HS Subaddress Register
+2EH	Reserved
+30H	Reserved
+32H	Reserved
+34H	IRQ Selection Register
+36H	Reserved
+38H	Load Clock HI Register
+3AH	Load Clock LO Register
+3CH	Reserved
+3EH	Reserved
+40H	Reserved
+42H	Current Address Register (CAR)
+44H	Trigger Occurrence Register (TOR)
+46H	Trigger Set-up Pointer (TSP)

6.2.1 Control Register (Write) (00H)

D15	D14	D13	D12	D11	D10	D09	D08	D07	D06	D05	D04	D03	D02	D01	D00
0	0	0	0	0	0	0	HR	0	IEN	IRQ	0	0	0	C1	C0

C0	Clear	=>	Command Request
C1	Clear	=>	Insertion Request
HR	Clear	=>	Hardware RESET

If IEN is set and IRQ is set then interrupt line will be cleared.

If IEN is set and IRQ is clear then the interrupt line will be asserted (for test purposes only).

If IEN is clear the value of IRQ is unaffected.

Note: This register must be accessed to clear the interrupt during an interrupt service routine.

- Examples:*
1. 0102H generates a command request.
 2. 0163H clears the interrupt line.

6.2.2 Command Register (CR)

Prior to clearing the Command Request bit (C0) in the Control Register, the user must first test that the CR is clear. When the CR is clear the user can insert the next command to be executed. Refer to table 6-2.

Table 6-2 Command Registers

CODE	COMMAND
0000H	Illegal
0001H	GO TO BCT MODE
0002H	GO TO MRT MODE
0003H	GO TO MON MODE
0004H	Reserved
0005H	Reserved
0006H	Reserved
0007H	Reserved
0008H	Reserved
0009H	Reserved
000AH	Reserved
000BH	Reserved
000CH	LOAD CLOCK
000DH	SELFTEST
000EH	RUN MONITOR
000FH	STOP MONITOR
0010H	SYNCHRONISE CLOCK

After the command is loaded, bit C0 in the Command register can be cleared. When the CR clears the board is ready for a new command.

6.2.3 Status Register (SR)

This register contains a code reflecting the status of the board as shown in table 6-3.

Table 6-3 Status Registers

CODE	COMMAND
0001H	Reserved
0002H	Reserved
0003H	MONITOR IDLE
0004H	Reserved
0005H	Reserved
0006H	Reserved
0007H	MONITOR RUNNING
0008H	Reserved

The Status Register will contain the following information after completion of selftest.

D15	D14	D13	D12	D11	D10	D09	D08	D07	D06	D05	D04	D03	D02	D01	D00
1	0	0	LS	0	0	LC	M5	M4	M3	M2	M1	1	0	0	0

- LS = 1 3838 Interface Test Failed
- FR = 1 Frame Counter Test Failed
- LC = 1 Local Clock Test Failed
- M5 = 1 Memory Test 5 Failed
- M4 = 1 Memory Test 4 Failed
- M3 = 1 Memory Test 3 Failed
- M2 = 1 Memory Test 2 Failed
- M1 = 1 Memory Test 1 Failed

If no selftest errors are detected the Status Register will be 8008H.

6.2.4 Transformer/Direct Coupling Select Register

If the LSB of this register is set to '1' the module will be configured for 3838 transformer coupling.
If the LSB of this register is set to '0' the module will be configured for 3838 direct coupling.

6.2.5 HS Subaddress Register

The least significant five bits of this register will define the RT Subaddress used by the system for HS transfers.

6.2.6 IRQ Selection Register (34H)

D15	D14	D13	D12	D11	D10	D09	D08	D07	D06	D05	D04	D03	D02	D01	D00
0	0	0	0	Trigger			Post Trigger			Full Stack			Half Stack		
				0	0	T	0	0	P	0	0	F	0	0	H

- T = If set, a physical INTA interrupt will be generated when the trigger condition is met.
- P = If set, a physical INTA interrupt will be generated when all the post trigger data is captured.
- F = If set, a physical INTA interrupt will be generated when the stack is full.
- H = If set, a physical INTA interrupt will be generated when the stack is half full.

6.2.7 Load Clock HI/LO Registers (+38H1 / +3AH)

If a LOAD CLOCK command is executed, these **two** registers define a 32-bit value to be loaded into the counter. If a SYNCHRONIZE CLOCK command is executed, the two registers define a 32 bit signed number to be added to the current clock value.

6.2.8 Current Address Register (CAR) (+42H)

This register contains the PAGE address of the current message being stored.

6.2.9 Trigger Occurrence Register (TOR) (+44H)

This register contains the PAGE address of the message that met the pre-programmed trigger condition.

6.2.10 Trigger Set-up Pointer (TSP) (+46H)

This register contains the absolute address of the trigger set-up data.

NOTE: This value is only 16 bits. All trigger set-up data **must** reside in the first 64Kbytes of the board.

6.2.10.1 Trigger Set-up Data

TSP Address

+00H Post Trigger Count Register (PTCR)

This register will contain the number of messages to be stored after the trigger condition is met. This value will be in the range 0000H to 8000H.

0000H = Stop immediately after trigger message.

8000H = Capture Forever.

+02H Selective Capture Count Register (SCCR)

This register will contain the number of messages to be stored when the monitor is in the Selective Capture Mode. This value will be in the range 0000H - 8000H.

20000H = 1 message.

8000H = Selective Capture Forever.

+04H Start Page Register (SPR)

This register will contain the desired PAGE address for the start of the monitor stack area.

+06H Finish Page Register (FPR)

This register will contain the desired PAGE address for the end of the monitor stack area. This value **must** be greater than the Start Page Register value.

+08H Window Word Count Register

This register will contain the word number in the specified message on which the window trigger test is to be carried out. If this value is zero, the test will be carried out on any word within the specified message.

+0AH 3910 Trigger Error Register

This register will define the error(s) in a 3910 message required for a trigger condition to occur. If more than one error is defined, the condition will be a logical OR of these errors. This register is only relevant when the monitor trigger is in 3910 mode.

D15	D14	D13	D12	D11	D10	D09	D08	D07	D06	D05	D04	D03	D02	D01	D00
D	0	0	0	0	0	0	0	0	0	W	F	P	E	R	B

W = Trigger on Word Count Error
F = Trigger on FCS Error
P = Preamble bit count error
E = Manchester encoding error
R = RI timeout (no HS response)
B = Bit count error

+0CH Hardware Trigger Register

D15	D14	D13	D12	D11	D10	D09	D08	D07	D06	D05	D04	D03	D02	D01	D00
0	0	0	0	0	0	0	0	0	0	0	0	C	T	N	P

P = 1 The Monitor will wait for LO-HI transition on the TRIG-IN input before storing messages and searching for the software trigger condition.

N = 1 The Monitor will wait for a HI-LO transition on the TRIG-IN input before storing messages and searching for the software trigger condition.

T = 1 The Monitor will generate a >1.5µS pulse on the TRIG-OUT when the software trigger condition has been detected.

C = 1 The Monitor will generate a >1.5µS pulse on the TRIG-OUT when the post trigger message count has been reached.

6.3 DETAILED TRIGGER DESCRIPTION

The Bus Monitor has four triggers that can be set up to trigger on a wide variety of complex conditions. Each trigger can be allocated one of four different data and error conditions. If a trigger passes this condition it then moves on to the trigger defined by the Pass register. If a trigger fails this condition it then moves on to the trigger defined by the Fail Register. Each trigger is allocated a trigger type value from one to six and these are as follows:

Value 1 Single Trigger Mode - The Single Trigger Mode will search for the trigger data defined by the Trigger Data Pointer Register. If this condition is TRUE for the incoming 3838 word the Single Trigger will branch to the trigger defined in the Pass Register. If it fails, it will branch to the trigger defined by the Fail Trigger Register.

Value 2 Window Trigger - The Window Trigger Mode will search for the trigger data defined by the Trigger Data Pointer Register within the first 3838 message it encounters. If this condition is TRUE for a word within the incoming message, the Window Trigger will branch to the trigger defined in the Pass Register. If the value of the Window Word Count Register is non zero the Window Trigger will use this value to specify the word number within the message for the Trigger test to be carried out. If this value is zero all words within the message will be tested. The Window Trigger would normally be preceded by a Single Trigger. The Single Trigger would define the specific 3838 command word, then pass to the Window Trigger to define a specific bit pattern of a particular word within this message. If the Window Trigger Fail Register points back to the Single Trigger requirements, then the monitor will start again with the next 3838 message.

Trigger 2:

Trigger 2 Type Register

@ Base Address +16H

This register will define the trigger type allocated to trigger 2.

This value will be the range 1 to 6.

Trigger 2 Data Pointer

@ Base Address +1 8H

This register will define the trigger data allocated to trigger 2.

This value will be the range 1 to 4.

Trigger 2 Pass Pointer

@ Base Address +1AH

This register will define the new trigger to be activated if this trigger condition passes.

This value will be the range 1 to 5.

Trigger 2 Fail Pointer

@ Base Address +1CH

This register will define the new trigger to be activated if this trigger condition fails.

This value will be the range 1 to 5.

Trigger 3:

Trigger 3 Type Register

@ Base Address +1EH

This register will define the trigger type allocated to trigger 3.

This value will be the range 1 to 6.

Trigger 3 Data Pointer

@ Base Address +20H

This register will define the trigger data allocated to trigger 3.

This value will be the range 1 to 4.

Trigger 3 Pass Pointer

@ Base Address +22H

This register will define the new trigger to be activated if this trigger condition passes.

This value will be the range 1 to 5.

Trigger 3 Fail Pointer

@ Base Address +24H

This register will define the new trigger to be activated if this trigger condition fails.

This value will be the range 1 to 5.

Trigger 4:

Trigger 4 Type Register

@ Base Address +26H

This register will define the trigger type allocated to trigger 4.

This value will be the range 1 to 6

Trigger 4 Data Pointer

@ Base Address +28H

This register will define the trigger data allocated to trigger 4.

This value will be the range 1 to 4.

Trigger 4 Pass Pointer

@ Base Address +2AH

This register will define the new trigger to be activated if this trigger condition passes.

This value will be the range 1 to 5.

Trigger 4 Fail Pointer

@ Base Address +2CH

This register will define the new trigger to be activated if this trigger condition fails.

This value will be the range 1 to 5.

Trigger Stop Register**@ Base Address +2EH**

This register will always be programmed to the value 6.
 This register is the STOP trigger sequence register.

Trigger Data 1:**Trigger Data 1 Bit Mask Register****@ Base Address +30H**

This register will define the bits to be ignored in the trigger bit pattern for trigger data 1.
 Any bit set in this register will be masked from the trigger test condition.

Trigger Data 1 Bit Pattern Register**@ Base Address +32H**

This register will define the bit pattern required for trigger data 1.

Trigger Data 1 Bus ID/Word Type Mask**@ Base Address +34H**

This register will define the Bus ID and Word Type bits to be ignored in the Bus ID/Word Type Register.

D15	D14	D13	D12	D11	D10	D09	D08	D07	D06	D05	D04	D03	D02	D01	D00
0	0	0	0	0	0	0	W	W	0	B	B	0	0	0	0

Both W bits = 1 Ignore Word Type in trigger condition.

Both B bits = 1 Ignore Bus ID in trigger condition.

Trigger Data 1 Bus ID/Word Type Register**@ Base Address +36H**

This register will define the Bus ID and Word Type for the trigger condition.

D15	D14	D13	D12	D11	D10	D09	D08	D07	D06	D05	D04	D03	D02	D01	D00
0	0	0	0	0	0	0	W	W	0	B	B	0	0	0	0

WMsb	WLsb		BMsb	BLsb	
0	0	Trigger on Command	0	0	Illegal
0	1	Trigger on Status	0	1	Trigger on Primary
1	0	Trigger on Data	1	0	Trigger on Secondary
1	1	Trigger on RT-RT Transfer	1	1	Trigger on Both Buses

Trigger Data 1 Error Word Mask Register**@ Base Address +38H**

This register will define if the Error Word Register is to be included in the trigger condition.

D15	D14	D13	D12	D11	D10	D09	D08	D07	D06	D05	D04	D03	D02	D01	D00
0	0	D	0	0	0	0	0	0	0	0	0	0	0	0	0

D = 1 Error condition disabled.

Trigger Data 1 Error Word Register**@ Base Address +3AH**

This register will define the Errors required in the trigger condition.

If more than one error is set, the trigger condition will be a logical OR of the errors.

D15	D14	D13	D12	D11	D10	D09	D08	D07	D06	D05	D04	D03	D02	D01	D00
0	0	0	Py	Mn	Lg	Sh	0	0	WC	0	0	NR	TA	Sy	0

Sy	= 1	Sync Type Error	Sh	= 1	Short Word Error
TA	= 1	Terminal Address Error	Lg	= 1	Long Word Error
NR	= 1	No Response Error	Mn	= 1	Manchester Error
WC	= 1	Wordcount Error	Py	= 1	Parity Error

Trigger Data 2:**Trigger Data 2 Bit Mask Register****@ Base Address +3CH**

This register will define the bits to be ignored in the trigger bit pattern for trigger data 2.

Any bit set in this register will be masked from the trigger test condition.

Trigger Data 2 Bit Pattern Register**@ Base Address +3EH**

This register will define the bit pattern required for trigger data 2.

Trigger Data 2 Bus ID/Word Type Mask**@ Base Address +40H**

This register will define the Bus ID and Word Type bits to be ignored in the Bus ID/Word Type Register.

D15	D14	D13	D12	D11	D10	D09	D08	D07	D06	D05	D04	D03	D02	D01	D00
0	0	0	0	0	0	0	W	W	0	B	B	0	0	0	0

Both W bits = 1 Ignore Word Type in trigger condition.

Both B bits = 1 Ignore Bus ID in trigger condition.

Trigger Data 2 Bus ID/Word Type Register**@ Base Address +42H**

This register will define the Bus ID and Word Type for the trigger condition.

D15	D14	D13	D12	D11	D10	D09	D08	D07	D06	D05	D04	D03	D02	D01	D00
0	0	0	0	0	0	0	W	W	0	B	B	0	0	0	0

WMsb	WLsb		BMsb	BLsb	
0	0	Trigger on Command	0	0	Illegal
0	1	Trigger on Status	0	1	Trigger on Primary
1	0	Trigger on Data	1	0	Trigger on Secondary
1	1	Trigger on RT-RT Transfer	1	1	Trigger on Both Buses

Trigger Data 2 Error Word Mask Register**@ Base Address +44H**

This register will define if the Error Word Register is to be included in the trigger condition.

D15	D14	D13	D12	D11	D10	D09	D08	D07	D06	D05	D04	D03	D02	D01	D00
0	0	D	0	0	0	0	0	0	0	0	0	0	0	0	0

D = 1 Error condition disabled.

Trigger Data 2 Error Word Register**@ Base Address +46H**

This register will define the Errors required in the trigger condition.

If more than one error is set, the trigger condition will be a logical OR of the errors.

D15	D14	D13	D12	D11	D10	D09	D08	D07	D06	D05	D04	D03	D02	D01	D00
0	0	0	Py	Mn	Lg	Sh	0	0	WC	0	0	NR	TA	Sy	0

Sy	= 1	Sync Type Error	Sh	= 1	Short Word Error
TA	= 1	Terminal Address Error	Lg	= 1	Long Word Error
NR	= 1	No Response Error	Mn	= 1	Manchester Error
WC	= 1	Wordcount Error	Py	= 1	Parity Error

Trigger Data 3:**Trigger Data 3 Bit Mask Register****@ Base Address +48H**

This register will define the bits to be ignored in the trigger bit pattern for trigger data 3.

Any bit set in this register will be masked from the trigger test condition.

Trigger Data 3 Bit Pattern Register**@ Base Address +4AH**

This register will define the bit pattern required for trigger data 3.

Trigger Data 3 Bus ID/Word Type Mask**@ Base Address +4CH**

This register will define the Bus ID and Word Type bits to be ignored in the Bus ID/Word Type Register.

D15	D14	D13	D12	D11	D10	D09	D08	D07	D06	D05	D04	D03	D02	D01	D00
0	0	0	0	0	0	0	W	W	0	B	B	0	0	0	0

Both W bits	= 1	Ignore Word Type in trigger condition.
Both B bits	= 1	Ignore Bus ID in trigger condition.

Trigger Data 3 Bus ID/Word Type Register**@ Base Address +4EH**

This register will define the Bus ID and Word Type for the trigger condition.

D15	D14	D13	D12	D11	D10	D09	D08	D07	D06	D05	D04	D03	D02	D01	D00
0	0	0	0	0	0	0	W	W	0	B	B	0	0	0	0

WMsb	WLsb		BMsb	BLsb	
0	0	Trigger on Command	0	0	Illegal
0	1	Trigger on Status	0	1	Trigger on Primary
1	0	Trigger on Date	1	0	Trigger on Secondary
1	1	Trigger on RT-RT Transfer	1	1	Trigger on Both Buses

Trigger Data 3 Error Word Mask Register**@ Base Address +50H**

This register will define if the Error Word Register is to be included in the trigger condition.

D15	D14	D13	D12	D11	D10	D09	D08	D07	D06	D05	D04	D03	D02	D01	D00
0	0	D	0	0	0	0	0	0	0	0	0	0	0	0	0

D = 1 Error condition disabled.

Trigger Data 3 Error Word Register**@ Base Address +52H**

This register will define the Errors required in the trigger condition.

If more than one error is set, the trigger condition will be a logical OR of the errors.

D15	D14	D13	D12	D11	D10	D09	D08	D07	D06	D05	D04	D03	D02	D01	D00
0	0	0	Py	Mn	Lg	Sh	0	0	WC	0	0	NR	TA	Sy	0

Sy	= 1	Sync Type Error	Sh	= 1	Short Word Error
TA	= 1	Terminal Address Error	Lg	= 1	Long Word Error
NR	= 1	No Response Error	Mn	= 1	Manchester Error
WC	= 1	Wordcount Error	Py	= 1	Parity Error

Trigger Data 4:**Trigger Data 4 Bit Mask Register****@ Base Address +54H**

This register will define the bits to be ignored in the trigger bit pattern for trigger data 4.

Any bit set in this register will be masked from the trigger test condition.

Trigger Data 4 Bit Pattern Register**@ Base Address +56H**

This register will define the bit pattern required for trigger data

Trigger Data 4 Bus ID/Word Type Mask**@ Base Address +58H**

This register will define the Bus ID and Word Type bits to be ignored in the Bus ID/Word Type Register.

D15	D14	D13	D12	D11	D10	D09	D08	D07	D06	D05	D04	D03	D02	D01	D00
0	0	0	0	0	0	0	W	W	0	B	B	0	0	0	0

Both W bits	= 1	Ignore Word Type in trigger condition.
Both B bits	= 1	Ignore Bus ID in trigger condition.

Trigger Data 4 Bus/Word Type Register**@ Base Address +5AH**

This register will define the Bus ID and Word Type for the trigger condition.

D15	D14	D13	D12	D11	D10	D09	D08	D07	D06	D05	D04	D03	D02	D01	D00
0	0	0	0	0	0	0	W	W	0	B	B	0	0	0	0

Wmsb	WLsb		BMsb	BLsb	
0	0	Trigger on Command	0	0	Illegal
0	1	Trigger on Status	0	1	Trigger on Primary
1	0	Trigger on Data	1	0	Trigger on Secondary
1	1	Trigger on RT-RT Transfer	1	1	Trigger on Both Buses

Trigger Data 4 Error Word Mask Register**@ Base Address +5CH**

This register will define if the Error Word Register is to be included in the trigger condition.

D15	D14	D13	D12	D11	D10	D09	D08	D07	D06	D05	D04	D03	D02	D01	D00
0	0	D	0	0	0	0	0	0	0	0	0	0	0	0	0

D = 1 Error condition disabled.

Trigger Data 4 Error Word Register

@ Base Address +5EH

This register will define the Errors required in the trigger condition.

If more than one error is set, the trigger condition will be a logical OR of the errors.

D15	D14	D13	D12	D11	D10	D09	D08	D07	D06	D05	D04	D03	D02	D01	D00
0	0	0	Py	Mn	Lg	Sh	0	0	WC	0	0	NR	TA	Sy	0

Sy	= 1	Sync Type Error	Sh	= 1	Short Word Error
TA	= 1	Terminal Address Error	Lg	= 1	Long Word Error
NR	= 1	No Response Error	Mn	= 1	Manchester Error
WC	= 1	Wordcount Error	Py	= 1	Parity Error

Trigger Start Register

@ Base Address +60H

This register defines the first trigger to be used in the trigger sequence.

This will be in the range 1 to 5.

Examples

The first trigger used in the sequence is defined by the contents of the Trigger Start Register. For these examples, assume that the Trigger Start Register points to Trigger 1 (value 1).

Key:

TTR	Trigger Type Register
TDP	Trigger Data Pointer
TPP	Trigger Pass Pointer
TFP	Trigger Fail Pointer
TSR	Trigger Stop Register

Example 1.

Find the word defined by Trigger Data 1, then save the number of messages defined by the PTC register.

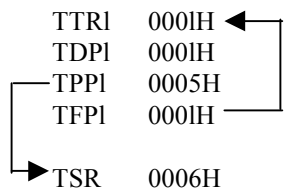

Example 2.

Find the message with word defined by the Trigger Data 2, followed by the Nth word within the message defined by the Trigger Data 4. Then, save the number of messages defined by the PTC register.

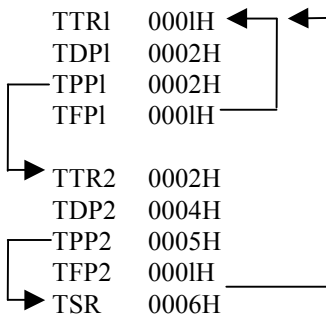

Example 3.

Find the message with word defined by Trigger Data 4 followed by the Nth word within the message defined by Trigger Data 1 by Trigger Data 3. i.e. Trigger on a specific 32 bit word.

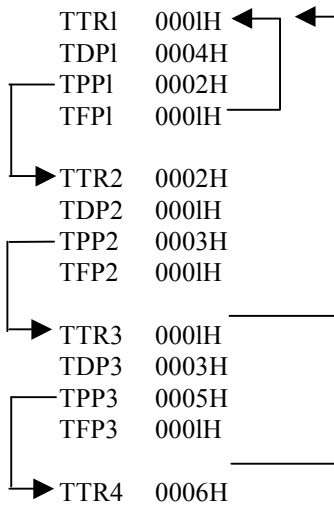

Example 4.

Find the message with word defined by Trigger Data 4 followed by the Nth word within the message defined by Trigger Data 1. Then, selectively capture all messages with word defined by Trigger Data 3, followed by word within the message defined by Trigger Data 2.

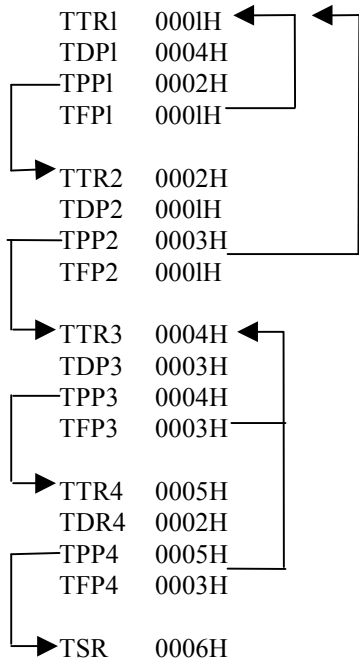

Example 5.

Find the message with word defined by Trigger Data followed by the Nth word within that message which **does not** meet the conditions of Trigger Data 2.

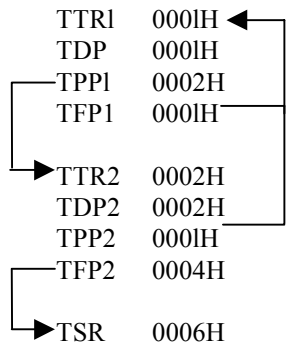

6.4 STACK DATA FORMAT

When the Bus Monitor is commanded to start, all messages will be stored before the trigger condition is met. Therefore, all pre-trigger data is captured. The first captured message will start at the address defined by the Start Page Register. All following messages will start on an even PAGE boundary. The STACK data will wraparound after the Finish Page Register value has been exceeded. The format of the messages are shown in table 6-4.

Table 6-4 Stack Data Format

WORD No.	NAME
1	Previous Address Pointer
2	Time Stamp HI
3	Time Stamp LO
4	Data
5	Errors
:	:
N-4	Data
N-3	Errors
N-2	RT Response Time 1 (LSB = 0.5 uS)
N-1	RT Response Time 2 (LSB = 0.5 uS)
N	Next Address Pointer

6.4.1 Previous Address Pointer

The first word of each message will define the page address of the previous message. The first message stored will set this pointer to 0000H.

6.4.2 Time Stamp HI/LO

These two locations are a 32-bit word defining the value of the 32 bit 0.5µS clock when the message started.

6.4.3 Data

These words describe the previous DATA word TYPE, BUS_ID and associated errors as follows:

D15	D14	D13	D12	D11	D10	D09	D08	D07	D06	D05	D04	D03	D02	D01	D00
ED	HS	OV	Py	Mn	Lg	Sh	T1	T0	WC	B1	B0	NR	TA	Sy	0

ED = 1	Indicates last 3838 word in message.
HS = 1	Indicates message has associated 3910 data. Only set for last word.
OV = 1	3910 DATA overlap. Decoder still active for previous 3910 message.
Py = 1	3838 data word had a Parity error.
Mn = 1	3838 data word had a Manchester error.
Lg = 1	3838 data word had too many bits (Long).
Sh = 1	3838 data word had too few bits (Short).

T1, T0 describe the 3838 word type as follows:

T1	T0	WORD TYPE
0	0	Command Word
0	1	Status Word
1	0	Data Word
1	1	RT-RT Command Word

WC = 1 Indicates 3838 message had a word count error. Only set for last word.

B1, B0 Describe the bus the 3838 word was captured on as follows

B1	B0	BUS ID.
0	0	Illegal
0	1	Secondary
1	0	Primary
1	1	Both Buses

NR = 1 Indicates that a RT failed to respond to a command (No Response).
Only set for last word.

TA = 1 Indicates that the RT status word did not match the address of the command word (Terminal Address Error).

Sy = 1 Indicates that the 3838 word did not have the correct SYNC type.

6.4.4 Next Address Pointer

This word will define the page address of the next message. This value will be set to FFFFH for the last message after the post trigger count has expired and capturing has stopped.

6.4.5 RT Response Time 1/2

These two locations will define the RT response times, if any, of the Status words in the message. The second Response time is only applicable for 3838 RT-RT transfers.

6.5 3910 DATA FORMAT

If a 3838 message results in the transfer of 3910 data, this message will be stored at the first new page after the 3838 message. The NEXT ADDRESS value in the 3838 data will account for this and point to the first page after the expected 3910 data. The first word in the 3910 data will describe the validity of the message as follows:

D15	D14	D13	D12	D11	D10	D09	D08	D07	D06	D05	D04	D03	D02	D01	D00
V	0	0	0	0	0	0	0	0	S	W	F	0	E	R	B

- V :- If set this indicates that the 3910 message is ready to be interrogated.
- W :- If set this indicates that the 3910 message had wordcount error.
- S :- If W is set then this shall indicate if the error was +ve or -ve (1 = -ve).
- F :- If set this indicates that the 3910 message had a FCS error.
- E :- If set this indicates that the 3910 message had a Manchester encoding error.
- R :- If set this indicates that the 3910 message had a RI timeout (no HS response).
- B :- If set this indicates that the 3910 message had a bit count error.

The following word in the stack will be H0000 for a 3910 message with no Word Count error (W bit clear). If the W bit is set this word will be a signed number defining the polarity (+1 = +ve, -1 = -ve).

The following words in the stack will be the received 3910 message as shown in table 6-5.

Table 6-5 Stack Messages

WORD No.	NAME
1	Frame Control / Physical Address
2	Destination Address
3	Word Count
4	Data
5	Data
6	Data
:	:
:	:
N-2	Data
N-1	Data
N	FCS

6.5.1 Flow Diagram

